

RED RHINO 5000 PLUS SERIES

OPERATION & MAINTENANCE HANDBOOK

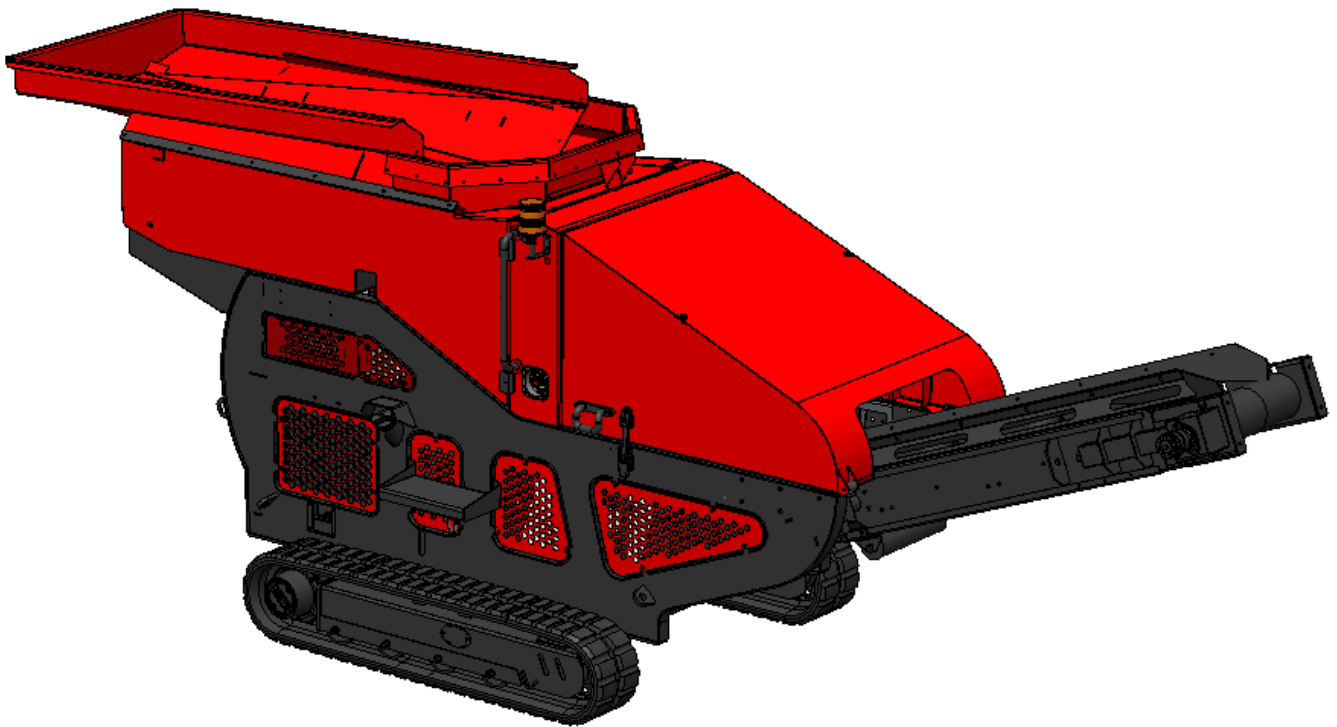

Serial Number	5200110
Date of manufacture	January 2022

Publication Number	511015
Publication Date	July 2022



Red Rhino
Crushers (UK) Ltd
Isaac Newton Way
Grantham
Lincolnshire
NG31 9RT
United Kingdom

Tel: +44 (0) 1476 590 790
E-mail: info@redrhinocrushers.net
Web: www.redrhinocrushers.com





The purpose of this manual is to give a quick reference to the owner and operators of the Red Rhino 5000 Plus.

For more Technical, Maintenance and Operational Information please refer to the following:

**Kubota Engine Operations Manual
Red Rhino Technical / Service Department**

Email: service@redrhinocrushers.net

Telephone: +44 (0) 1476 590 790

Contents

Terms & Definitions.....	5
Warranty.....	6-8
Warranty Registration and Installation Certificate.....	9-10
EU Declaration of Conformity.....	11
Introduction to the Handbook.....	12-14
Warning Labels & Symbols.....	15
Stopping the Machine in an Emergency.....	16
Component Locations.....	17
General Safety.....	18-20
Operating Safety.....	21-22
Maintenance Safety.....	23
Operation Instructions/ Environment	24-25
Crushing	26/27
Operation Instructions.....	28
Pre-Start Safety Checks.....	29/31
Engine Controls.....	32-33
Remote Handset.....	34-35
Radio Receiver.....	36
Discharge Conveyor.....	37-38
Dust Suppression.....	39
Vibrating Feeder.....	40
Feeder Lubrication Detail.....	42
Running Gears (Tracks).....	43-44
Jaw Crusher Unit.....	45-46
Guide to Servicing Your Machine.....	47-51
Hydraulic Manual Controls.....	52
Hydraulic Circuit.....	53
Electrics.....	54-58
Options Menu.....	59-62
Replacement Parts.....	63
Model Specifications.....	64
General Arrangement Dimension.....	65
Noise Emissions.....	66-68
Glossary.....	69

Terms & Definitions

For the purposes of this document, the terms and definitions given in ISO 6165 and the following apply.

Left-hand side

Side which is on the left when an observer is facing in the normal forward direction of travel of the machine.

[ISO 3600:1996]

Right-hand side

Side which is on the right when an observer is facing in the normal forward direction of travel of the machine.

[ISO 3600:1996]

Operator's manual

Document describing and illustrating the safe operation, maintenance and safety precautions related to an earthmoving machine.



Warranty

Warranty Terms, Conditions & Procedures-

Warranty Terms and Conditions.

Your Red Rhino 5000 Plus series Compact Crusher has been designed and manufactured in the UK and meets all current EU legislations on safety, emissions and noise levels. The product is warranted against any defects in material and workmanship for a period of 1 year or 1000 hours usage, from date of installation, whichever occurs first.

This warranty is subject to:

Adherence to the routine maintenance procedures, as detailed in the instruction book, the use of genuine Red Rhino parts and approved lubricants.

Adherence to the service schedule, undertaken by Red Rhino Crushers (UK) Ltd or an approved Red Rhino service agent, using genuine Red Rhino parts and approved lubricants.

Adherence to the requirement to utilize and record service actions with Red Rhino Crushers (UK) Ltd service record documentation, and to supply Red Rhino Crushers (UK) Ltd with originals of service record documentation.

Return (within 30 days) of a signed collection/delivery note confirming acceptance of goods in satisfactory condition, and all warranty registrations including: The Red Rhino Warranty Registration & Installation Certificate and Kubota engine manufacturers Warranty Certificate.

Adherence to the correct warranty claim procedure as stated below, including the provision of a valid purchase order number by the customer, and utilization of a valid Red Rhino Crushers (UK) Ltd reference number.

Subject to adherence to the above conditions and during the warranty period, any failed parts will be supplied free of charge, except for the following limitations:

Warranty Limitations:

The following items are consumable parts and not covered by warranty:

1. Tracks.
2. Battery & starter motor.
3. Wear parts - crusher jaws, conveyor belts, toggle-plate, drive belts, conveyor roller lagging, internal and conveyor rubber wear parts.
4. Paintwork.
5. Warranty exclusions as determined by the engine manufacturer:
6. Service parts - filters, glow-plugs, fanbelts, fuel injection equipment, stop solenoid, leaks (oil, water, and air) hoses, coolants and lubricants. Brake parts (where applicable).

The warranty does not extend to cover normal routine maintenance, cleaning, or servicing, nor any materials used to carry out routine servicing. The buyer hereby acknowledges and accepts that any costs incurred on repairs, mileage or servicing required outside of warranty periods or in the event that a warranty claim is rejected, will be chargeable at our standard rates. (Please contact us for further information).

All engine warranty issues must be directed to the engine manufacturer or the engine manufacturers approved / appointed engine dealer. No liability shall be attached to us where repairs cannot reasonably be affected, or where following partial repair, a fault or breakdown occurs in the parts or portion not repaired.

The warranty liability of Red Rhino Crushers (UK) Ltd is restricted in all cases to the repair or replacement of the defective part (s), and no liability is accepted for consequential damage or any other expense, loss, or costs (including loss of profit). Red Rhino Crushers (UK) Ltd may actuate the repair or provide compensation in the form of a credit note only, for labour incurred in actuating the repair. In all cases, a credit note for labour will only be provided for the replacement or repair of the defective part (s) and in accordance with the time allowances detailed in the Red Rhino workshop manual and limited in all cases to the standard hourly rate mentioned above.

The warranty does not apply to defects caused by accident, misuse, neglect or wear and tear.

Red Rhino Crushers (UK) Ltd warranty does not cover any indirect loss and/or expense or costs (including loss of profit), and Red Rhino Crushers (UK) Ltd are not liable for any such costs, loss or expense suffered arising out of a breach by Red Rhino Crushers (UK) Ltd of this contract.

The equipment is checked for contaminants in fuel, oils and lubricants prior to dispatch. If routine service or warranty work reveals any contamination in the fuels, engine, or hydraulic system, then the works carried out to amend the problem will be chargeable and not included within warranty.

The warranty is not transferable without written authority from Red Rhino Crushers (UK) Ltd.

Red Rhino Crushers (UK) Ltd cannot recognize any liability, in cases where alterations or modifications have been executed or replacement parts fitted other than those approved without prior knowledge and consent in writing from Red Rhino Crushers (UK) Ltd.

Red Rhino will not be held responsible if:

- The machine has been used to perform tasks that demand more than its design and strength limitations.
- Modifications, alterations, or the use service parts, consumables or lubricants which are not genuine or recommended will invalidate any warranty.
- The machine has undergone modifications not approved in writing by Red Rhino Crushers (UK) Ltd, or conditions of use have been abnormal.
- The conditions of warranty supply listed above have not been met.
- Warranty does not extend to cover normal maintenance, cleaning, or servicing, nor any materials used to carry out routine servicing.

Function

The 5000 series: for the crushing and recycling of secondary debris and demolition waste materials of a size not exceeding the dimensions of the jaw-bite aperture. Not for primary mineral extraction. Not for use with reinforced material containing metals, or contaminants such as wood, clay, metal, plastics, wet cement, textiles, asbestos, tarmac, etc.

Subject to the function and conditions of use stated, the 5000 series should be capable of handling the following;

- Mineral crush typically found within recycling and demolition areas.
- Materials typically pre-formed such as brick and composite base.
- Materials also shaped from mineral solids such as stone and block work.

CONDITIONS OF USE: (for standard units) **

The 5000 series compact crusher is designed for use only in the following conditions:

Temperature: Do not operate the crusher in temperatures below minus 15°Centigrade or above plus 40°Centigrade.

Environment: The 500 Series crusher is designed for use outside only, in normal humidity conditions only.

Platform: Firm, level ground only.

Personnel: Only to be used by trained personnel.

Atmosphere: Operate only in clean, unpolluted air, and do not operate in excessive wind speeds, or abnormal altitude.

Duration: maximum 12 hours operation in any 15-hour period

Operation: Use only with correct loading methods and with correct loading equipment (not exceeding 7t excavator or equivalent), as detailed in the Operation Manual.

Maintenance: use only if serviced in accordance with the service and maintenance schedules outlined in the Operation Manual, utilizing only genuine parts and lubricants.

Transportation: For use only in accordance with all applicable legal transportation restrictions.

Legislation: for use only in accordance with all relevant and applicable legislation and regulations. **

** Please refer to the engine manual supplied for the restrictions imposed upon the engine for the limitations of the environment (temperature, altitude, humidity, etc) in which the engine can be operated.

Warranty Audits and Surveys

Red Rhino Crushers (UK) Ltd reserves the right to carry out audits and inspections from time to time in relation to any reimbursed or outstanding warranty claims in order to determine that all relevant details and information is correct.

Service & Warranty Training

Service & Warranty training for service fitters can be requested in writing to

service@redrhinocrushers.net

Initial training will be carried out at an appropriate Red Rhino Crushers (UK) Ltd workshop. Once this initial training has been carried out, you are responsible to carry out further training as required by your own service centre, and to record service actions in accordance with Red Rhino Crushers (UK) Ltd service record documentation.

Service Bulletins

Red Rhino Crushers (UK) Ltd may from time to time issue service bulletins to keep you up to date as to any developments or changes that take place on the complete assembly or component parts.

Warranty Registration and Installation Certificate

Warranty Claim Procedures:

Installation:

It is mandatory that the Warranty Registration and Installation Certificates are completed, signed and returned by the original purchaser to Red Rhino Crushers (UK) Ltd. This is essential for the Red Rhino Warranty Registration & Installation Certificate, and Kubota engine manufacturers Warranty Certificate. Warranty commences from date of collection from our premises.

Terms:

Red Rhino products are warranted against defect in material and workmanship for a period of 12 months or 1000 working hours from the date of installation, whichever occurs first. The engine is warranted for a period of two years.

Warranty Claim Submission Procedure:

The warranty liability is limited to diagnosis, repair or replacement of the defective part. Depending on the product terms and conditions, and subject to the above, Red Rhino Crushers (UK) Ltd may actuate the repair or provide compensation in the form of a credit note only, for labour incurred in actuating the repair. In all cases, a credit note for labour will only be provided for the replacement or repair of the defective part (s) and in accordance with the time allowances detailed in the Red Rhino workshop manual, and limited in all cases to the standard hourly rate aforementioned.

Claims must be reported accurately, and all relevant details given, as follows:

- OWNERS NAME AND ADDRESS: full name and address of customer and site location if different
- SERIAL NUMBER:
- MACHINE TYPE:
- DATE OF PURCHASE:
- DATE OF DELIVERY/COLLECTION:
- ENGINE NUMBER:
- HOURS USED:
- DATE OF FAILURE:
- CUSTOMER PURCHASE ORDER NUMBER: (This must be supplied)
- RED RHINO CRUSHERS (UK) LTD REF NO: (This must be quoted)

Please contact Red Rhino for a Claim Form.

Warranty Registration and Installation Certificate

MODEL: _____

SPECIFICATION: _____

SERIAL NUMBER: _____

DELIVERY DATE: _____

I confirm that I have been instructed on the safe use of the Red Rhino Crusher or Screener as detailed above, and that I have retained and read a copy of the operator instruction manual in full and that I understand the terms of the warranty.

Purchased From: _____

Date: _____

Name: _____

Signed: _____

Position: _____

Company Address _____

Tel: _____

Email: _____

Web: _____

IT IS ESSENTIAL TO RETURN THIS FORM TO ACTIVATE AND REGISTER YOUR WARRANTY. FAILURE TO RETURN ANY OF THE WARRANTY REGISTRATION FORMS WILL INVALIDATE WARRANTY. (See "Contents" page).

Please complete the following form to register your warranty and post to:

Red Rhino Crushers (UK) Ltd
Isaac Newton Way
Alma Park Road
Grantham
Lincolnshire
NG31 9RT
United Kingdom

EU Declaration of Conformity

We hereby certify that the machinery detailed below complies with all the relevant provisions of the EC Machinery Directive as amended and the National Laws and Regulations adopting this directive.

Machine Description:

Track mounted compact diesel/hydraulic powered jaw crusher for recycling all types of aggregate based building materials.

MAKE: Red Rhino Crusher

MODEL: 5000 Plus Series

SERIAL NUMBER:

ENGINE NUMBER:___NAME of MANUFACTURER:

Red Rhino Crushers (UK) Limited
Isaac Newton Way
Alma Park Road,
Grantham,
Lincolnshire,
NG31 9RT,
United Kingdom.
T: +44 (0) 1476 590 790
E: info@redrhinocrushers.net
W: www.redrhinocrushers.com

Conforms to the Machinery Directive; 2006/42/EC and amended directive 95/16/EC (re-cast).

Conforms to Electromagnetic Compatibility Directive (EMC); 2004/108/EC

Conforms to Radio Equipment Directive (RED); 2014/53/EC

It also complies with the Essential Health and Safety Requirements (EHSR), national standards and transposed harmonized standards appropriate for this product type.

BS ISO 21873: 2009 Building Construction Machinery and Equipment- Mobile

BS EN1009: Machines for mechanical processing of minerals and similar solid materials.

Crushers, parts 1 & 2

SIGNED: ... 

DATE:November 2022.....

NAME: Andrew Hall

POSITION: Operations Manager – *(Being the responsible person appointed by the Manufacturer.)*



Red Rhino Crushers (UK) Ltd

Declaration of Conformity

In accordance with UK Government Guidance



Product Model/Type

Product Red Rhino

Model 5000Plus

Serial Number 5200110

Manufacturer Red Rhino Crushers (UK) Ltd

Address Isaac Newton Way, Alma Park Industrial Estate, Grantham, Lincs, NG31 9RT

This declaration is issued under the sole responsibility of the product manufacturer.

The object of the declaration described above is in conformity with the relevant UK Statutory Instruments and their amendments.

We hereby declare that the product described above, to which this declaration of conformity refers to, is in conformity with the essential requirements of the following standards.

Reference & Date
Conforms to the Machinery Directive 2006/42/EC and amended directive 95/16/E
Conforms to Electromagnetic Compatibility Directive (EMC) 2004/108/EC
Conforms to Radio Equipment Directive (RED) 2014/53/EC
It also complies with the Essential Health and Safety Requirements (EHSR), national standards and transposed harmonized standards appropriate for this type
BS ISO 21873 2009 Building Construction Machinery and Equipment Mobile
BS EN1009 Machines for mechanical processing of minerals and similar solid materials

Additional Information The technical documentation for the machinery is available from:

Red Rhino Crushers (UK) Ltd

Isaac Newton Way, Alma Park Industrial Estate, Grantham, Lincs, NG31 9RT

Signed for & on behalf of Red Rhino Crushers (UK) Ltd

Date of Issue -----January 2023-----

Andrew Hall

Name -----

Operations Manager

Position -----

Signature -----

Introduction to the Handbook

This handbook covers the following models in the Red Rhino Crusher range:

5000 Plus

The above machine is designed primarily for the crushing of waste construction material and aggregate for recycling purposes or ease of transportation

Modifications or alterations to the machine are strictly forbidden without the prior written consent of Red Rhino Crushers (UK) Ltd.

If the machine is used in any way contrary to its intended use, or if the machine is modified or altered in any way without the prior written consent of Red Rhino Crushers (UK) Ltd, or if the machine is incorrectly or recklessly driven, operated or maintained, Red Rhino Crushers (UK) Ltd will not accept any liability whatsoever for any damage or injury (whether direct or consequential).

The methods of operation and maintenance specified in this handbook must be strictly adhered to.

For your parts requirements it is essential that only Red Rhino Crushers (UK) Ltd genuine parts are fitted.

Any damage resulting from the fitment of non-genuine parts will invalidate the machine warranty.

The content of this handbook whilst correct at the time of publication may be subject to alteration by the company at any time without notice.

Red Rhino Crushers (UK) Ltd operates a policy of continuous improvement and reserve the right to change specification and equipment without notice. Therefore, some illustrations and accompanying text may differ slightly from your machine.

References to Left or Right contained in this handbook are as seen from the rear of machine forward. Depicted in page 5.

Introduction to the Handbook

The contents of the Operators Handbook are intended as a guide to the operation and servicing of the-

5000 Plus.

The general method of operation of all these machines is the same. Any individual differences in the specification or operation are detailed separately.

This handbook is not a training manual.

It is designed as a guide to the machine's controls and working capacities and general maintenance only. It must not be removed from the machine and should be kept clean and in good condition always.

Additional copies of the handbook can be obtained from Red Rhino Crushers (UK) Ltd.

Only trained operators should use this machine. Red Rhino Crushers (UK) Ltd strongly recommends that anyone who is responsible for the operation and servicing of this machine be a fully trained & competent operator.

If you have any doubts about any aspects of the machine's capability or servicing procedures, you must consult Red Rhino Crushers (UK) LTD.

Throughout this handbook and on the machine, there are safety notes. Each note starts with a single phrase.

The meaning of these single phrase are explained below.



Safety Warnings

This safety alert system identifies important safety messages in this manual. When you see this symbol, be alert, your safety is involved, carefully read the message that follows, and inform other operators.

In this publication and on the machine, there are safety notices; each notice starts with a signal word meaning are provided below.



Danger

Denotes an extreme hazard exists. If proper precautions are not taken, it is highly probable that the operator (or others) could be killed or seriously injured.



Warning

Denotes a hazard exists. If proper precautions are not taken, the operator (or others) could be killed or seriously injured.

**Caution**

Denotes a reminder of safety practices could result in injury to the operator (or others) and possible damage to the machine.

In general, these notes are used to indicate that the procedures being described in the handbook must be followed to avoid serious injury or death, to yourself or others. The notes are also used to protect the machine from unsafe servicing practices.

These notes do not replace safety codes, insurance requirements & local laws. Make sure the machine has the correct equipment to comply with local regulations.

Pay particular attention to the safety notes given throughout the handbook.

It is the responsibility of the Operator to fully read all of the handbook & understand it before attempting to operate the machine.

Warning Labels & Symbols

Danger of Trapping



Emergency Stop

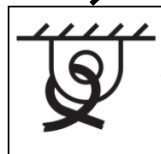

Tie Down Points

Wear P.P.E.



Stopping the Machine in an Emergency



Warning

- The machine can be stopped in an emergency by pressing the emergency stop buttons located along each side of the machine or by turning the ignition key directly to the “off” position.
- Make sure that all persons in the area of the machine are fully trained in the location of the emergency stops and how to use them.

How to Operate an Emergency Stop;



**PRESS THE
RED BUTTON
FIRMLY TO
STOP.**

To rest the Emergency stop.
Turn the Emergency stop
clockwise and release.



**TURN IGNITION
TO OFF**

Component Locations

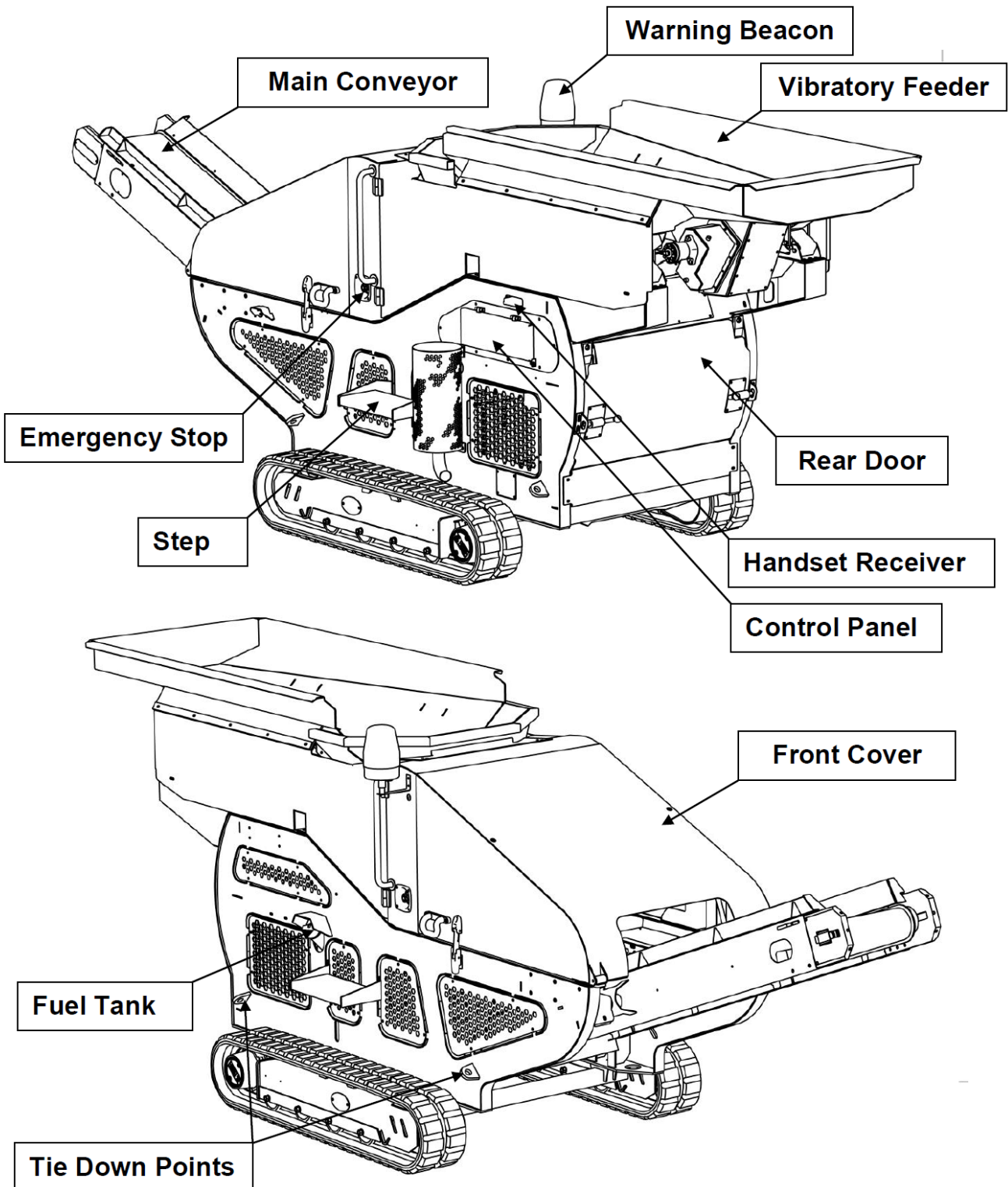

General Safety



Warning

To operate the machine safely you must know the machine and have the skills to use it. You must abide by all relevant laws, health and safety regulations that apply to the country you are operating in.

The operator manual instructs you on the machine, its controls and its safe operation.



Warning

You and others could be killed or seriously injured if you operate or maintain the machine without first studying the operator manual. You must understand and follow the instructions in the operator manual. If you do not understand anything, ask your employer or Red Rhino dealer to explain it.



Warning

Care and alertness:

All the time you

- Are working with or on the machine, take care and stay alert.
- Always be careful.
- Always be alert for hazards.



Warning

Clothing:

- You can be injured if you do not wear the proper clothing. Loose clothing can get caught in the machinery.
- Wear protective clothing to suit the job. Examples of PPE are: a hard hat, safety shoes, safety glasses, a well-fitting overall, ear-protectors and industrial gloves.
- Keep cuffs fastened.
- Do not wear a necktie or scarf.
- Keep long hair restrained.
- Remove rings, watches and personal jewelry.



Warning

Alcohol and drugs:

- It is extremely dangerous to operate machinery when under the influence of alcohol or drugs.
- Do not consume alcoholic drinks or take drugs before or while operating the machine at any time.
- Be aware of medicines which can cause drowsiness or alter focus.



Warning

Feeling unwell:

- Do not attempt to operate the machine if you are feeling unwell. By doing so you could be a danger to yourself and those you work with.



Warning

Mobile Phones:

- Switch off your mobile phone before entering an area with a potentially explosive atmosphere; Sparks in such an area could cause an explosion or fire resulting in death or serious injury.
- Switch off and do not use your mobile phone when refueling the machine.



Warning

Raised Machine:

- Never position yourself or any part of your body under a raised machine which is not properly supported; if the machine moves you could become trapped and suffer serious injury or be killed.



Warning

Machine Modifications:

- This machine is manufactured in compliance with legislative and other requirements. It should not be altered in any way which could affect or invalidate any of these requirements.



Caution

Machine Operator:

- This machine must be operated only by correctly trained and authorised personnel. Certain local operating conditions may require the machine operator to obtain an operator's licence or a certificate.



Caution

Magnetic Hazard:

- If this machine is fitted with an over band magnet must not operated by any personal with a pacemaker. Otherwise this could result in death or serious injury.



Warning

Lifting:

- This machine is **NOT** permitted to be lifted for transport or any other reason.



Warning

Power Source:

- Before any maintenance, service or adjustments are carried out on the machine the "POWER SOURCE" must be isolated. Any persons carrying out repairs or maintenance must isolate the machine and remove the ignition control key.

Isolator as shown below-

The Isolator is positioned inside the rear engine access door on the left hand side, top position.



Operating Safety



Warning

Machine Condition:

- A defective machine can injure you or others. Do not operate a machine which is defective or has missing parts. Make sure the maintenance procedures in this manual are completed before using the machine.



Warning

Airborne Debris:

- Airborne articles can be ejected during the crushing process. Erect an exclusion zone with barriers at a safe distance around the machine.
- Do not let unauthorized people enter this exclusion zone.



Warning

Exhaust:

- Breathing the machine exhaust gases can harm and possibly kill you. Do not operate the machine in closed spaces without making sure that there is good ventilation. If you begin to feel drowsy, stop the machine and get into fresh air.
- The exhaust pipe becomes extremely hot when the engine is running and will remain so for some time after the engine is stopped. If you touch the hot pipe you could be severely burned.



Warning

Work Site:

- Work sites can be hazardous. Inspect the site before working on it. You could be killed or injured if the ground gives way under your machine or if piled material collapses onto it. Check for potholes and hidden excavations etc. Any of these could cause you to lose control of your machine.
- Do not work or drive too close to banks and trenches where there is danger of collapse.
- Ensure that you have enough clearance beneath overhead cables and structures.



Warning

Noise:

- Noise generated by the machine can cause permanent hearing damage over periods of time; hence we strongly recommend all users to wear ear protection at all times.



Warning

Communication:

- Bad communications can cause accidents. Keep people around you informed of what you will be doing. If you will be working with other people, make sure any forms of signaling and communication such as, hand signals that may be used are understood by everyone.



Warning

Transportation:

- Make sure that any trailer or vehicle is suitable to transport the machine and meets all road traffic regulations.
- Before moving the machine onto a trailer or vehicle, make sure that load bed and ramps are free from oil, grease, ice and mud.
- Ensure that the ramp angle does not exceed that in the technical details.



Warning

Hazardous Atmospheres:

- This machine is designed for use in normal outdoor atmospheric conditions. It should not be used in an enclosed area without adequate ventilation.
- Do not use the machine in a potentially explosive atmosphere.



Warning

Moving Components:

- The machine has rotating parts. Switch OFF the engine before working in the engine compartment.
- Do not use the machine with the engine cover open.



Warning

Machine Safety:

- Stop work at once if a fault develops.
- Abnormal sounds and smells can be signs of trouble. Inspect and repair before resuming work.



Warning

Electric Circuits:

- A competent operator/engineer must first understand the electric circuit before connecting or disconnecting an electrical component
- To avoid injury or damage get the work done by a competent operator/engineer.



Warning

Fire

- Machine fires must **not** be put out using water. Always use foam, dry chemical or carbon dioxide extinguishers.

Maintenance Safety



Warning

Repairs:

- If your machine does not function correctly in any way, get it repaired straight away. Neglect of necessary repairs could result in an accident or affect your health.
- Do not try to do repairs or any other type of maintenance work you do not understand.
- To avoid injury and/or damage get the work done by a competent engineer



Warning

Electric Repairs:

- Do not try to do repairs or any other type of maintenance work you do not understand or are not fully trained in.
- To avoid injury and/or damage get the work done by a competent engineer



Warning

Battery:

- Batteries give off an explosive gas. Do not smoke when handling. Keep away from all flames and sparks
- Battery electrolytes contain sulphuric acid; it can burn you if in contact with your eyes or skin. Wear goggles and handle carefully to avoid spillages.
- Keep metallic items away from terminals; they can short the terminals and burn you.
- Set all switches to OFF before removing the battery; when removing, remove the earth (-) lead first.
- The battery earth terminal is fitted with a screw-in isolator to facilitate a safe system for working on the crusher.
- Charge the battery away from the machine in a well-ventilated area. Switch off the charging circuit before connecting/ disconnecting the battery.
- When you have installed the battery in the machine, wait five minutes before connecting it up.
- When reconnecting, fit the positive (+) lead first.

Operating Instructions

Introduction -

This section of the manual aims to provide you with full knowledge of your machine required for efficient and safe operation. Ensure this section is read fully before using the machine. If any part is unclear please consult your employer or Red Rhino Dealer.

Once read and understood, practice with the machine in an open space, clear of any hazards or people to ensure you are comfortable with the machine and understand all the controls before use in a work environment.

Quick Tips:

- Use the same loading operator – only familiarity with loading will achieve the maximum tonnage per hour.
- Position the excavator higher to allow a clear line of site into the jaws – a micro excavator is recommended.
- Use a maximum 10 inch bucket on a micro excavator. This can be used to gauge and pre-sort the material.
- Choose the appropriate jaw setting – For example. if crushing 50mm slabs the jaws must be set to less than 50mm to avoid slabs falling through and obstructing the belt.
- Save up oversized material. Feed these into the jaws one at a time (or break these up with a bucket / breaker).
- Load parallel down the slope of the hopper directly in-line with the jaw. The best tonnage will only be achieved with a “little but often” technique. Do not be tempted to overload the hopper or jaw as this will slow down overall production.
- Set the correct speed for the crusher and conveyor.
- Ensure all recommended tips are communicated with any new operators.
- Be mindful to not load material into the crusher which will not cause blockages, damage your conveyor belt or contaminate your aggregate. This may include; metals, wet materials and similar.
- If you require product output of 20mm, it may reduce production time to crush in stages. For example: first crush down to 100mm then refeed and crush down to 20mm.
- Note: jaws should be free from material prior to turning off your 5000 ES to avoid product blockages and potential damage.

Operating Environment

Introduction -

This machine is designed to operate in temperatures between -15°C and 40°C.

Operating in a Cold Climate (Below 0°C)

To account for extremely low temperatures ensure extra time is provided for the warm up of the crusher. Following the warm up time ensure that the crusher and conveyor are functioning correctly before use. Ensure the machine is cleaned of excess water after use.

Preparing the Machine for Travel

When travelling on site it is your responsibility to ensure that you are in compliance with any local regulations or rules concerning transporting the machine.

Working with your Machine

- Before taking the machine onto a site you must ensure conditions are good and safe for the machine and there are no potential hazards in moving the machine.
- Ensure the machine is in good working order and all maintenance and servicing has been maintained to date.
- Ensure the Crusher is placed in an open area on even and dry ground.
- Only operate the machine if the operator's manual has been fully read. Make sure you understand and you are fully confident of operating the machine.
- Whilst operating the machine be aware crushing will create dust.
- For optimum output maintain a constant steady uninterrupted flow of material. It is recommended you use the same loader to get use to the machine and discover what the best load of material is.

Moving the Machine

Before moving the Crusher ensure the machine has finished crushing and the machine is free of material from the hopper, crusher box and conveyor. The Crusher can be moved with a suitable forklift using the fork pockets at the base of the crusher.

Crushing

All crushing should be done on a level surface-



Safety Warnings

- Crushing machine uses powerful moving jaws so under no circumstances should the machine run without all covers attached or when moving parts are exposed.



Safety Warnings

- Under no circumstances should you attempt to remove blockages by hand.
- When the crusher is running you may begin to feed material into the hopper either manually or by machine, ensuring not to overfill the hopper. A steady and constant flow of material will produce maximum crushing efficiency so ensure you take your time to find the best filling procedure.
- Once you have finished crushing your material ensure the hopper, crusher box and conveyor are all clear of material then you can stop the crusher simply by returning the switch on the controls to neutral.

Adjusting Crushers Jaws -

Output size of the crushed material may be varied by reducing or increasing the jaw spacing suitably.



Safety Warnings

- Never attempt to adjust the jaw size of the crusher whilst the crusher is running, or material is still in the crusher; ensure the crusher is both clear and not running before attempting to adjust otherwise you will risk damage to your crusher.
- The crushing jaw can be adjusted hydraulically using the touch panel or on the remote handset. Once adjusted be sure to attempt a small amount of material to determine if the output size meets your requirements.

Excavator Specification Advised -

Maximum Bucket Capacity	Excavator	Loading Position
12 - 22 inches / 304.8 - 558.8mm	2-12 Tone	Side to Rear of Feeder

Crushing Materials -

Suitable Materials for Crushing:

- Possible crushing materials include stones, rocks, bricks, concrete, kerb stones and general construction rubble.
- It may be possible to also crush steel reinforced concrete though you should first consult your Red Rhino dealer in order to determine if your machine is capable.
- If unsure of a material for crushing consult your Red Rhino dealer for information.

Unsuitable Materials for Crushing

- The machine will not crush wood, plastic, fresh blacktop (tarmac), clay or wet mud. Whilst these items will not damage your crusher jaws, they will contaminate your reusable aggregates, cause blockages and reduce crushing time.
- The conveyor belt is a consumable item, and as such is not covered by warranty. You should avoid any metal/ steel items entering your crusher. These items will damage the conveyor belt.
- It is advisable to inspect the stockpile from time to time and remove any of the above items manually.
- Material which is longer than 380mm will need to be fed into the jaws lengthways – material which is wider than 215mm will be too wide for the maximum jaws setting.



Caution

- Attempting to crush any of these materials will put you under serious danger and risk of serious if not fatal injury.

Unblocking Crusher Jaws:

- In the event the crusher becomes blocked or material is failing to pass through the crushing jaws; under no circumstances should you attempt to enter or reach into the crusher.
- The jaw adjustment feature, via remote-control can be utilized to open the jaws and release blocked/ bridged material. Never close-up the jaws unless the jaws are completely empty.
- Similarly bridges/blockages can be freed by reversing the direction of the jaw plates using the reverse option on the crusher controls switch. Do not attempt to change the crusher direction until the crusher has come to a complete stop.

Operation Instructions

Gradient

Transportation:

When loading the Machine for transport, the ramp must ***not*** exceed 25°. It should also be noted that ground conditions should be taken into consideration as to whether the conditions are wet or slippery because this will greatly reduce this value.

Travelling:

When moving the machine slope of the ground should ***not*** exceed 15°. It should also be noted that ground conditions should be taken into consideration as to whether the conditions are wet or slippery because this will greatly reduce this value.

Tie Down:

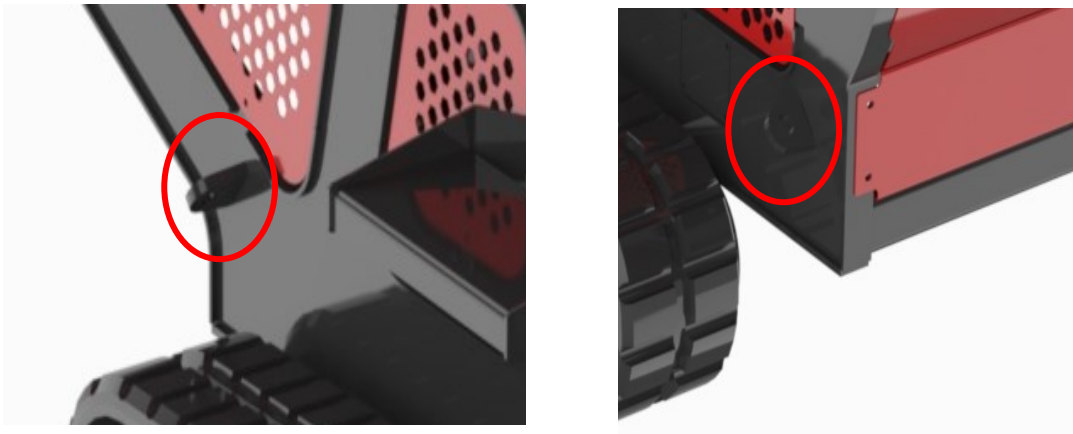

Highlighted above are the location points of the tie downs.

The tie down points can be found on the front and back on both sides of the crusher, these points should be used to secure the machine for transportation.



Safety Warnings

The tie down points should ***never*** be used to lift or tow the machine.

Pre-Start Safety Checks

The following checks must be carried out prior to commencing work.

Particular attention must be given if the machine has been left idle for any period of time.

All of these checks concern the continued operation of the machine and some concern your safety. Any defects should be inspected and corrected by your distributor or service engineer.



Warning

- **Never** commence work with the machine until a full pre-start safety check has been carried out.



Warning

- **Only** trained competent operators can operate this machine.

1. Check the engine oil level.
2. Check the hydraulic oil level.
3. Check the fuel level.
4. Check the air cleaner condition.
5. Check the remote handset is charged.
6. Check the coolant level.
7. Turn ignition on and ensure no malfunction errors are shown.
8. Check that no one is within 15 meters of the machine.
9. Proceed to start.

For further technical information please refer to the Kubota Engine Operators Manual.

Guidance to Machine Pre-Start Checks

Engine Oil Dipstick



Hydraulic Oil Level Gauge



Fuel Level Gauge





Air Cleaner Element



Filter Element

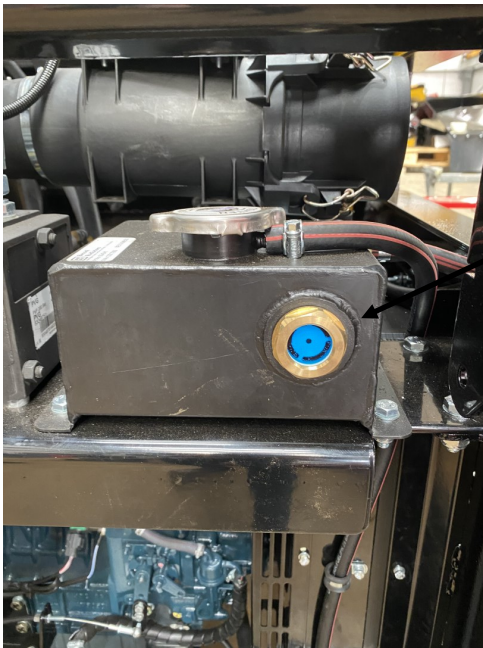

Coolant Level Indicator

Remote Handset Charge Adaptor



240 V Charger

Engine Controls

Control Panel-



The control panel box (shown above) is located on the nearside rear enclosure of the machine. Please refer to the following pages for an in depth breakdown of the control panel.

Throttle Control -



The throttle lever, which controls the Engine Speed (shown above) can be found on the rear nearside enclosure of the machine.

Control Panel Indication Lights-

<p>Engine Temperature Indicator</p> <p>Illuminates to show the engine temperature is too high, cooling fan belt is slipping, broken or the cooler/matrix is blocked.</p>		<p>Engine Running</p> <p>When illuminated & the key is in the ON position or the engine is running.</p>
<p>Air Filter Indicator</p> <p>When illuminated the air filter is blocked.</p>		<p>Charge Indicator</p> <p>Indicates alternator operation, illuminates when there is a fault.</p>
<p>Pre-Heat</p> <p>The light will illuminate for 10 seconds then turn off. After 10 seconds turn ignition to starting position.</p>		<p>Engine Oil Pressure</p> <p>When illuminated the engine oil pressure is too low.</p>
<p>E-Stop Indicator</p> <p>when illuminated an emergency stop switch is depressed or the front cover is open.</p>		<p>Remote E-stop</p> <p>Indicates that the stop is depressed on the remote control. Or the remote control has lost communication with the crusher.</p>

Key Switch Controls-

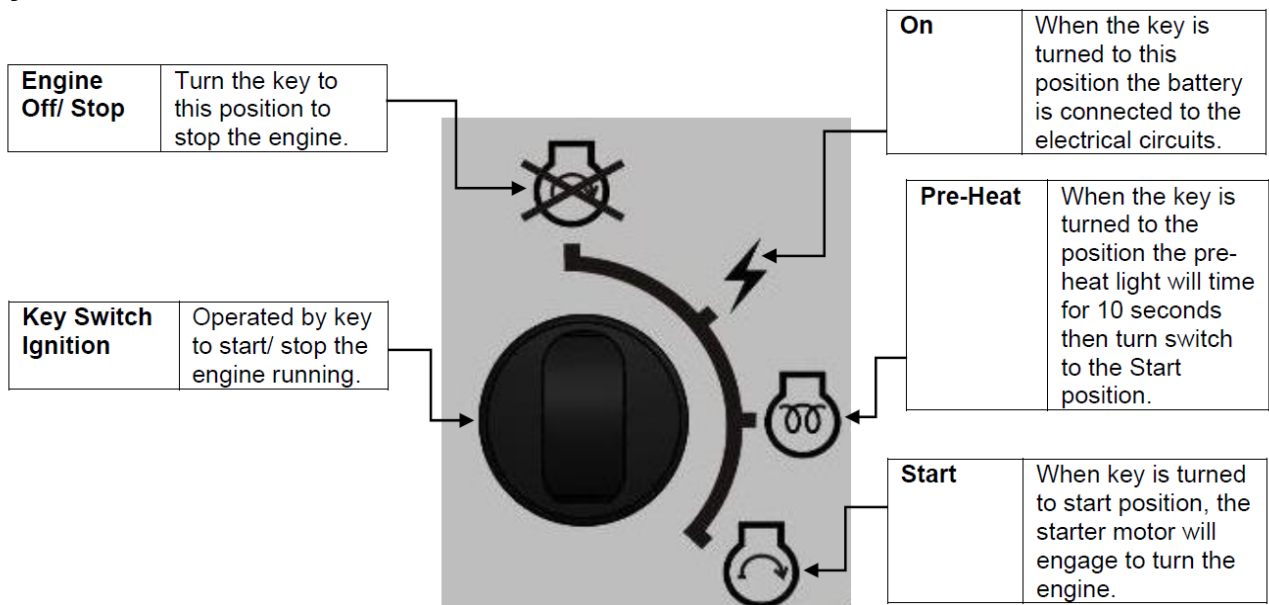

Hours Run Counter-



Records the total running time of the engine.

Remote Handset

The Remote Handset operates the machine via the radio receiver. This handset has a charging adaptor for mains current charging. For radio operation the handset must be kept charged.

If the handset battery becomes flat the umbilical cord connection can be used. Please refer to the umbilical cord connection picture below.

The picture and diagram on page show the remote handset functions.

PLEASE SEE THE CONTROL SYSTEM MANUAL FOR FULL USER INSTRUCTIONS.

Remote Handset-

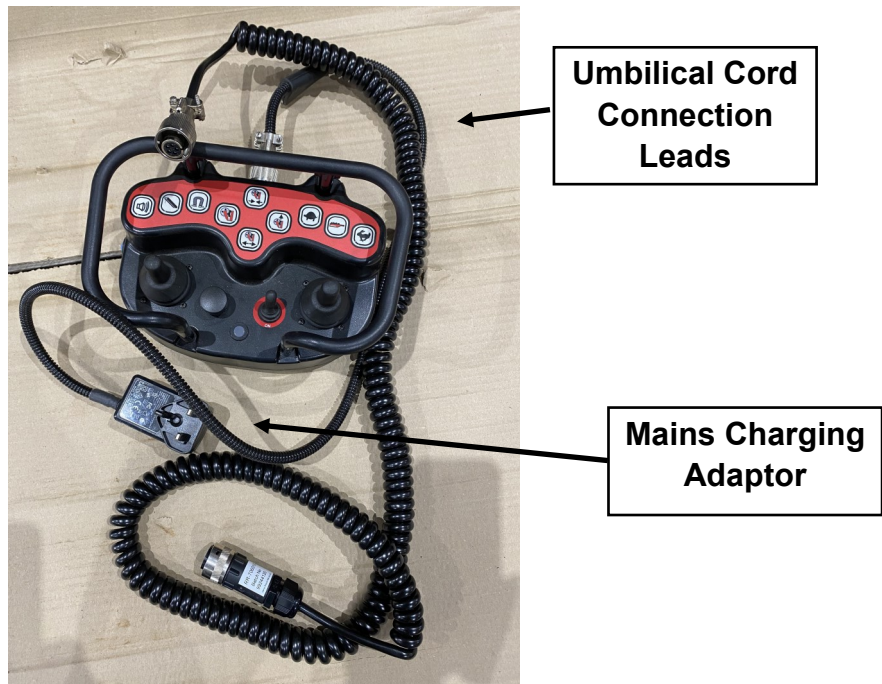

Umbilical Cord Connection Point

There is also an umbilical cord connection to the machine for manual control this is located under the control panel as shown in the picture below.



Remote Handset

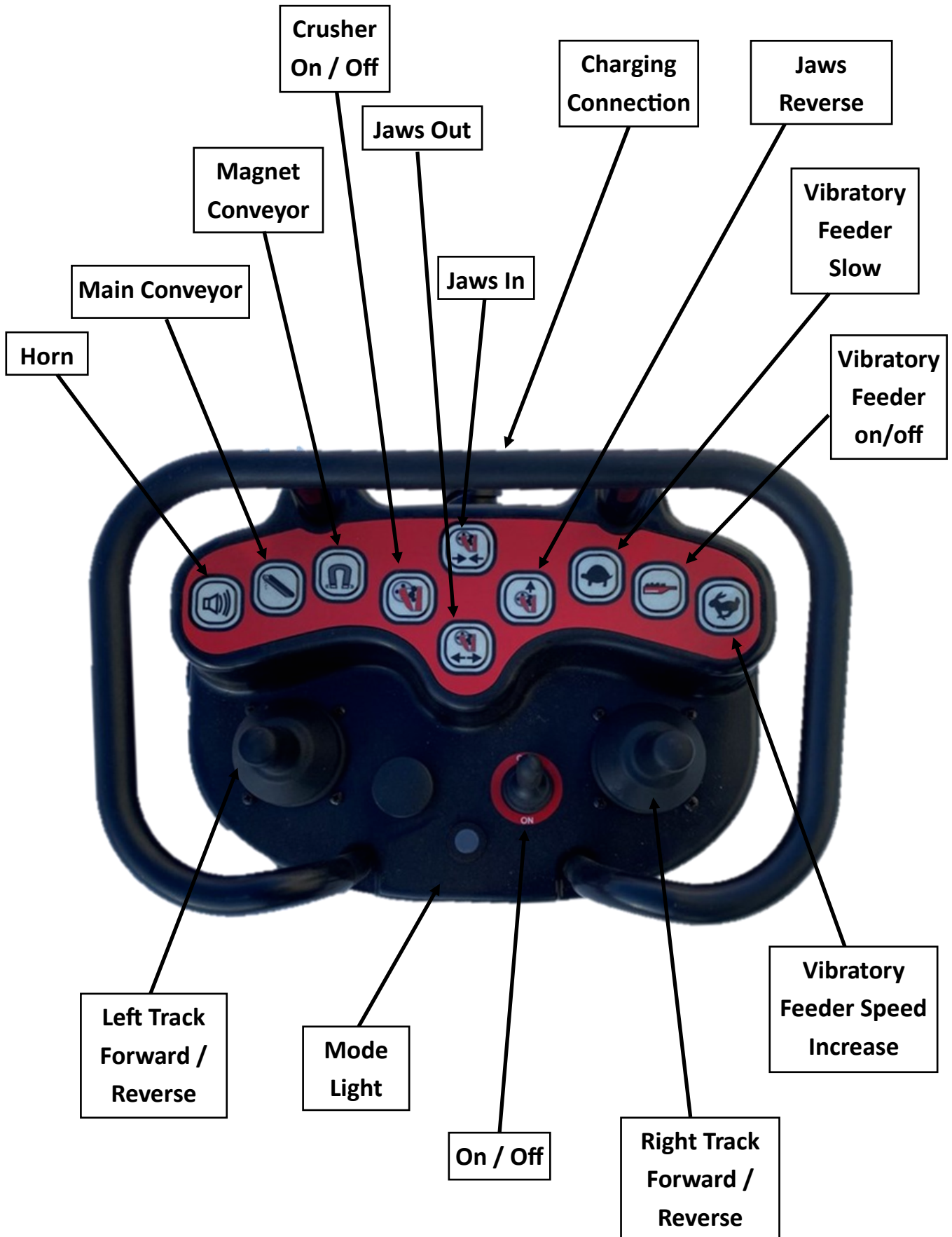

Discharge Conveyor

Starting the Conveyor system -

Before attempting to crush any material, you should first ensure that the conveyor is running so there will not be a build-up on material in the crusher.

The conveyor is started by using the touch pad on the remote control, when using the radio remote control the conveyor will stop after 30 seconds if the remote signal is lost.



Safety Warnings

- Do not place hands near conveyor whilst in operation; conveyor belt can cause injury whilst running if due care and attention is not taken.



Danger

- It is against the law to crush any materials deemed flammable, explosive, or toxic. It is against the law to crush asbestos.
- DO NOT attempt to crush metals.

Conveyor Belt

Checking the condition of the conveyor belt:

The conveyor belt should be checked for any cuts or wear that may indicate it needs to be replaced, regularly.

Checking and adjusting the conveyor belt:

Check the conveyor belt in operation. The belt should be inspected visually to ensure there is no slippage on the rollers and the belt is running true. Should the belt require tightening, at the end of the conveyor, there are tension adjusters on the left hand and right-hand sides.

Note: The belt should be tightened carefully to ensure both sides are adjusted equally so the conveyor will still run true, also the belt should never be over tightened, do leave around 50mm slack at the centre of the belt beneath the conveyor. If unsure, advice can be given from our service engineers.

**Conveyor Belt
Tension Adjusters**



**Side Wear
Rubber
Skirting**



Conveyor

The Conveyor is fitted with side wear rubber skirting to prevent any spillages.

Grease Point

Coupling

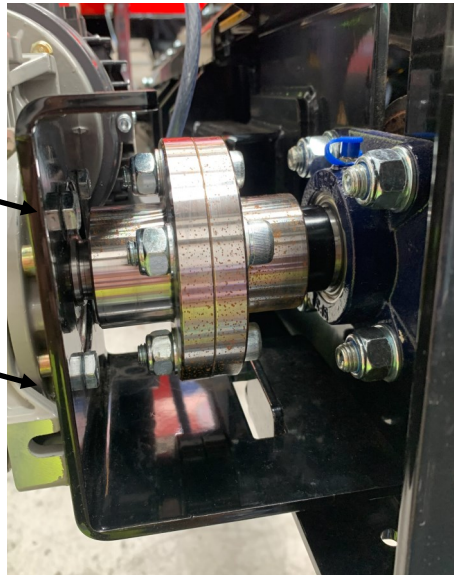

Conveyor Grease Point

The Head-drum Bearings are fitted with grease points left hand side and right hand side.

Conveyor Motor Drive Assembly

The Conveyor drive coupling is a direct drive assembly and requires no maintenance.

Conveyor Removal

- The Conveyor assembly is an easily removed unit. It is advised to regularly remove to clean out any crushed debris which has collected in the lower tail end of the conveyor.



Safety Warnings

Do not place hands near conveyor whilst in operation; conveyor belt can cause injury whilst running if due care and attention is not taken.

Dust Suppression

**Spray Bar
& Nozzles**



Dust Suppression

A dust suppression water spray bar is mounted above the conveyor discharge belt. This cross belt assembly is fitted with three water nozzle jet valves.

**Water Supply
Connector
Point**



Connection Point

A mains water supply is required to connect to the spray bar. This connection point is on the outer left hand side of the machine.



Warning

Airborne Debris:

- Airborne articles can be ejected during the crushing process. Erect an exclusion zone with barriers at a safe distance around the machine. Do not let unauthorized people enter the exclusion zone.

Vibrating Feeder

The Vibrating Feeder is capable of handling a wide range of products, such as minerals, aggregates, recyclables and limestone.

The feeder is Hydraulically driven and vibration is controlled by the feeder pan being mounted on 4 x Vibrating Rosta Mounts.

The feeder additionally has a fixed drive gearbox at the rear of the unit.

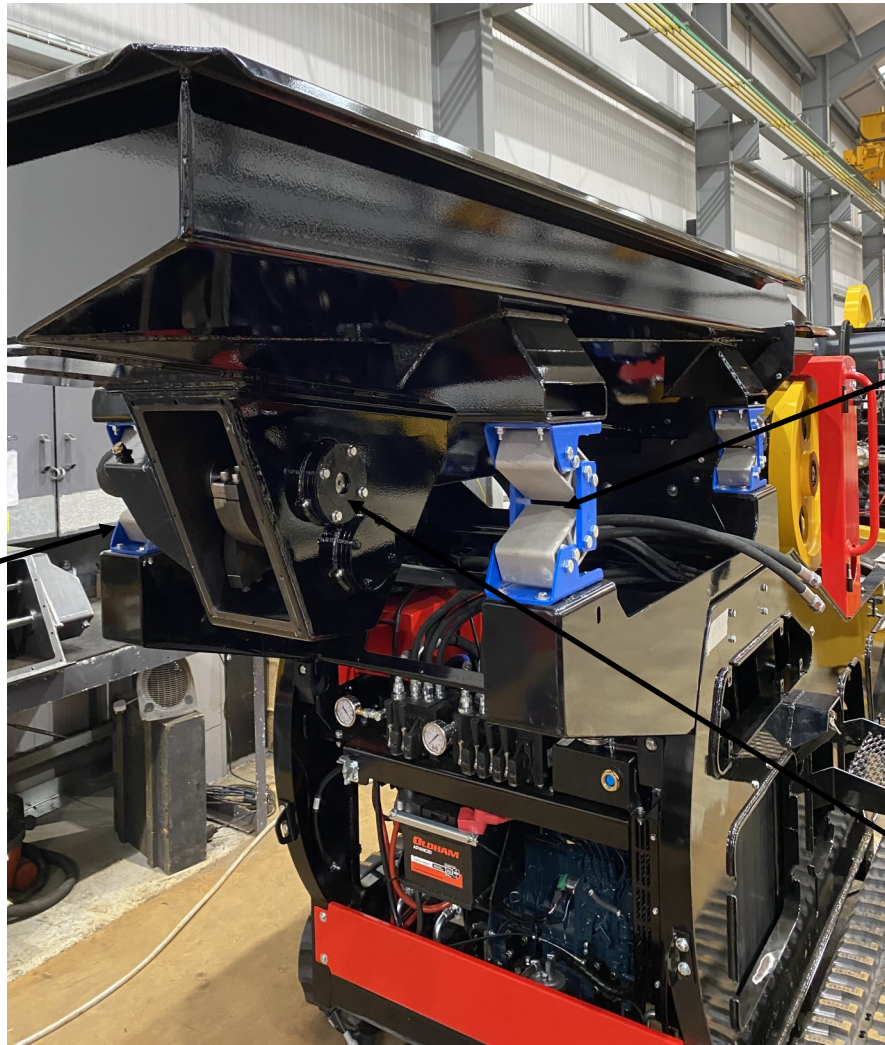

Feeder
Gearbox

Rosta
Mount

Grease
Point



Safety Warning

The feeder should not be used if:

- Any of the Rosta Mounts are broken
- There is a build up of material in the feeder pan
- If any components are loose or excessively worn
- If the hydraulic motor is excessively noisy
- If the drive vibrator oil level is low
- The Stop / Start control is not working

Feeder Lubrication Detail

Oil Filler /
Breather Plug

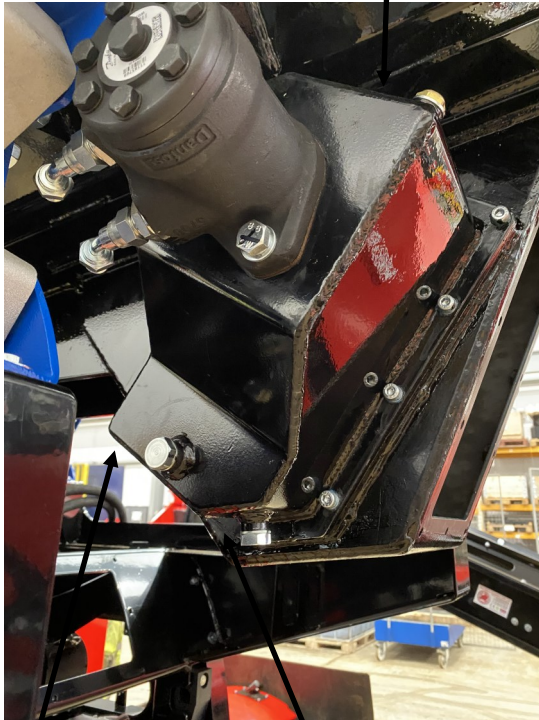

Oil Level
Plug

Oil Drain
Plug

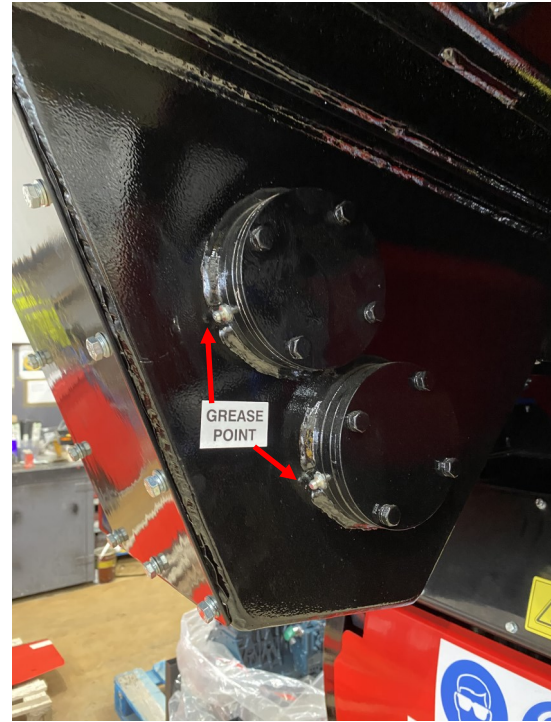

The feeder only requires the oil level to be maintained and the bearings to be greased on occasion.

Oil Level - The Oil Level plug should be checked every 250 hours and the correct level must be maintained. The oil should be level with the plug threads when removed. Please use good quality EP 150 gear oil. Total amount of oil from empty is 200ml.

Greasing – The shaft bearings will require grease top up via the grease nipples every 3000 hours of operation. Recommended grease is Esso Unirex N3.

Feeder Stop / Start

The feeder is equipped with a Stop / Start button control. This is used for the operator to stop the flow of material manually into the jaw if excessive material builds up from the feeder.



Running Gear (Rubber Tracks)

Checking tracks for cuts and abrasions:

Whilst visually inspecting the tracks, attention should also be taken for any signs of wear on the tracks such as damage that may indicate the tracks need to be replaced.

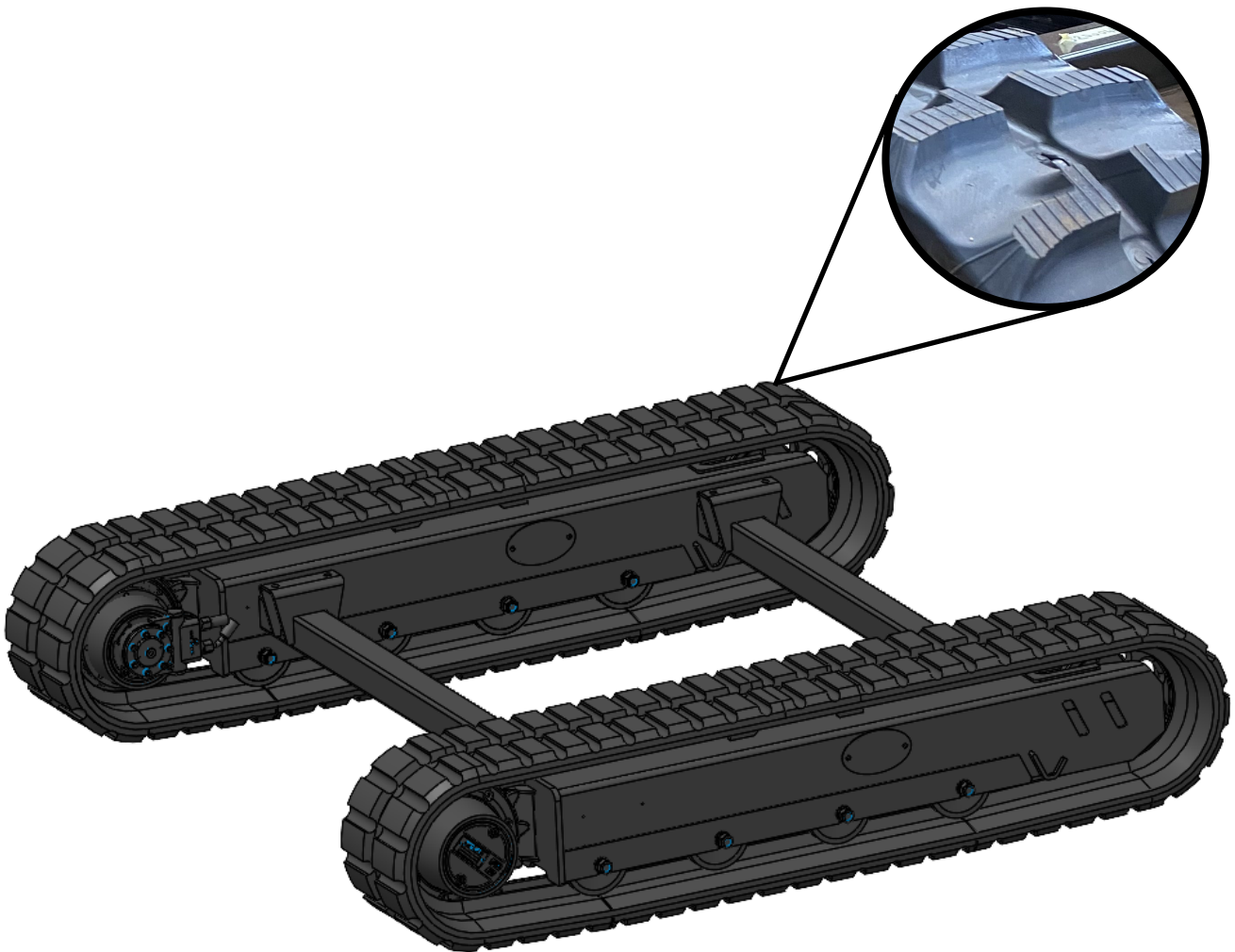

Warning

- Grease under pressure can cause serious injury. Never unscrew a Track Adjuster Valve by more than a ½ turn, when the Track is under tension.

Running Gears (Tracks)

Track Adjustment

After maintenance or over time the Track will become slack and will have to be adjusted. The adjustment of the tracks operates through a Tensioning Cylinder (C). When the Cylinder is filled with grease it extends and pushes the Spring Tension unit (B), and the Idler (A), forward. The grease is filled through the Track Adjuster Grease Valve (D).

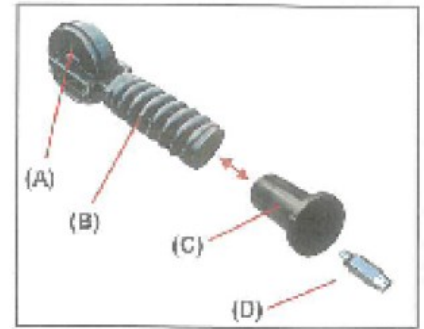

Track Adjustment Settings

In order to establish if the track requires tensioning move the Host machine a few meters forwards and backwards on level ground. This allows the tracks to adopt their natural degree of tension.

Note: Do not slew the machine

Using a straight edge and a tape measure, measure the droop of the Track Group, as shown in E. For this particular Track Set, the droop should not exceed 20mm.

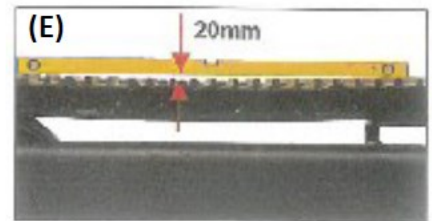

Note: It is also important that the Track is not tensioned too tightly as this places excessive loads on the Gearbox and Idler bearings. It will also lead to accelerated wear and premature failures.

Increasing the Track Tension

To increase the tension of the Track:

1. Remove the inspection cover on the side of the Track Frame, as shown in (F).
2. Ensure that the Track Adjuster Valve (H) is tight.
3. Attach the special grease gun connector (G) to a grease gun and fit it onto the Track Adjuster Valve (H).
4. Pump grease into the valve until the droop of the Track is correct.
5. Move the Host machine backwards and forwards a few times more and recheck the droop. Add more grease if required.
6. Check for any escaping grease around the Tensioning unit and close the inspection cover when finished.



Important Note: Ensure that the correct grease is used.

Releasing the Track Tension

1. Remove the inspection cover on the side of the Track Frame, as shown in (F).
2. Loosen the Track adjuster valve, (H), by turning it one half turn anti-clockwise.
3. Grease should now escape slowly from the Track Tensioning Cylinder and the Track should slacken.
4. If the Track fails to loosen apply a little pressure to the idler end of the Track to push the Idler group in.
5. Replace the inspection cover when completed.

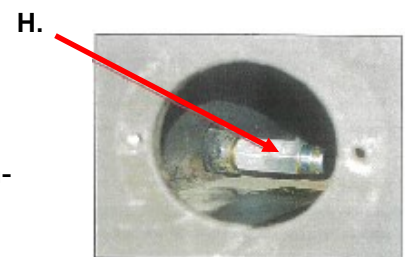

Gear Box Oil Level

Important: Cleanliness is essential when checking, filling or replacing oil in the gearbox. Gearbox operating life will be dramatically shortened if the oil becomes contaminated. Only use new clean oil in clean containers and fillers.

A. Check and Filling Gearbox Oil

1. Move the Host Machine to a level surface and bring the oil fill and oil drain holes to the position shown at (A).
2. Thoroughly clean around both plugs removing all potential contaminants.
3. Remove both plugs.
4. Fill the oil through the left hand side hole until it runs out of the right hand side hole.
5. Wait a few moments until any trapped air has escaped and re-check the level. Add more oil if necessary.

Note: The gearbox should hold approximately 0.40 litres of SAE 90 oil.

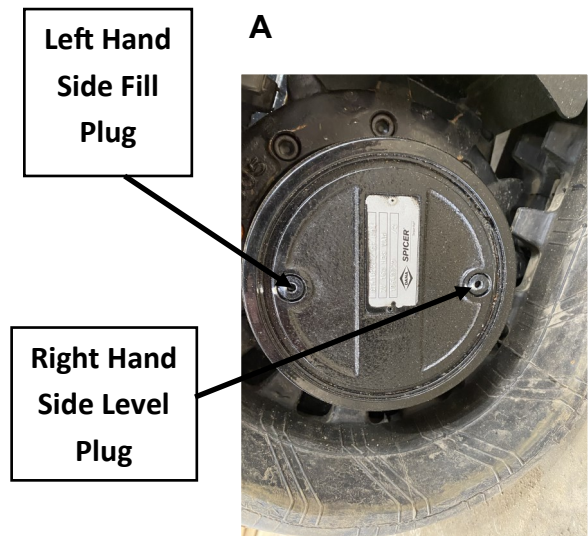

Filling Oil

B. Draining Gearbox Oil

1. Move the Host Machine to a level surface and bring the oil fill and oil drain Holes to the position shown at (B).
2. Thoroughly clean around both plugs removing all potential contaminants.
3. Remove both plugs and allow the oil to drain. The oil will drain quickly if it is hot, however, care should be taken to avoid burns to the operator.
4. **Note: Dispose of used oil safely and in an environmentally friendly manner.**
5. Move the machine to bring the plugs to the fill position, as shown at (A).
6. **Important:** Do not move the machine any further until the oil has been replaced into the gearbox.
7. Re-fill the oil as per the above sectioned (Checking and Filling Gearbox Oil).

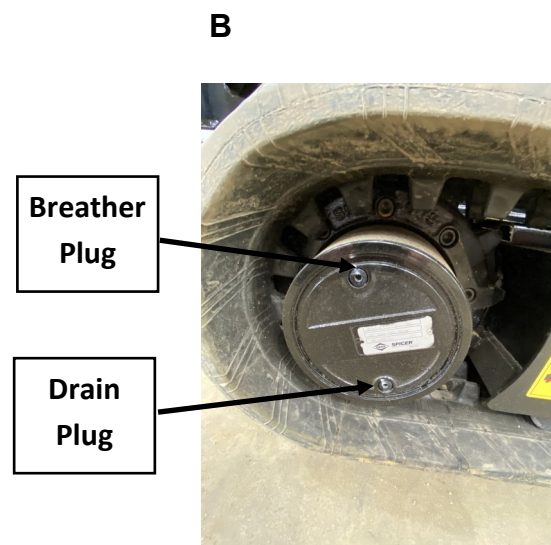

Draining Oil

Jaw Crusher Unit

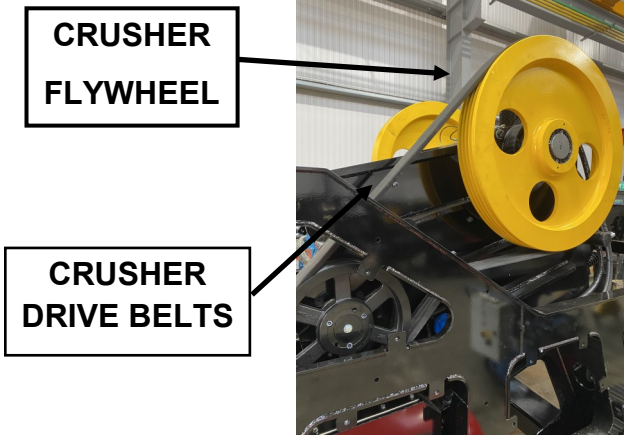

Jaws Unit

The Jaw Crusher Unit is an integral part of the crusher and is situated centrally within the chassis.

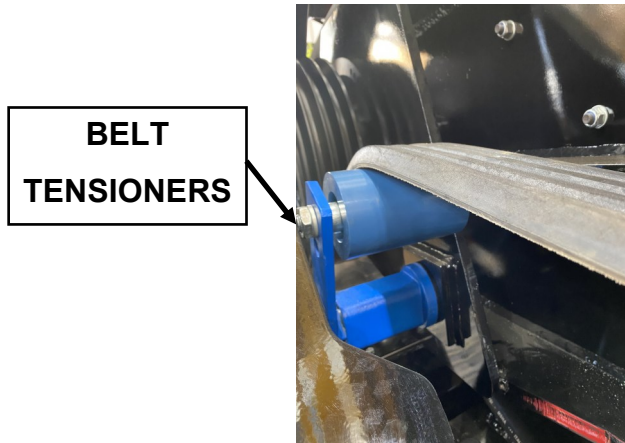

Power

The crusher is hydraulically driven via flywheels, belt and tensioner to give the crusher reciprocating motion.

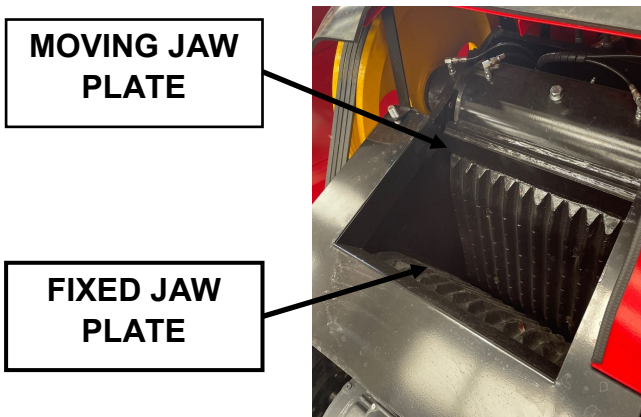

Jaw Plates

The Crusher unit consists of fixed and moving jaw wear plates. These are a wearing part which will need replacing after time and can be reversed for maximum use.



Warning Danger

- The Jaw Plates are loose when securing wedge and bolts the nuts are not installed and tightened and the jaw plate could fall and cause a serious injury, death or damage the equipment. Make sure it is held in position when the lifting tools are removed. Make sure persons are **never** in the jaw box or between the jaw plates.

**HYDRAULIC
RAM**



Motion & Sizing

Hydraulic rams are operated from the remote control. This operates a wedge system to narrow or widen the bottom opening of the jaw. This adjustment allows the sizing of the discharge crushed material.

**GREASING
POINTS**



Greasing Bearings

The crusher box has a central greasing point for the inner and outer bearings, situated under the main bonnet canopy on the left hand side of the machine.

Recommend greasing every 250 hours.

**TOGGLE
PLATE**

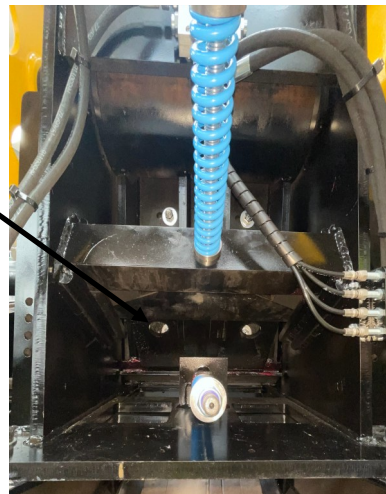

Crusher Toggle Plate

This protects the Crusher from loads generated by uncrushable objects.

The "Toggle Plate" is a protection device and will collapse or bend when crushing loads are exceeded.

The Toggle Plate is a replacement spare part.



Warning

Moving Components:

- The machine has rotating parts. Switch OFF the power source before working in the compartment.

Guide to Servicing Your Machine

For full engine service details, please refer to the Kubota Engine Manual

For service and technical assistance please contact RRC;

Email: service@redhinocrushers.net

Telephone: +44 (0) 1476 590790

Engine

The engine oil dipstick and oil drain plug are accessible through the rear engine access door at the front of the engine. The engine oil filter is on the rear side of the engine below the alternator assembly.

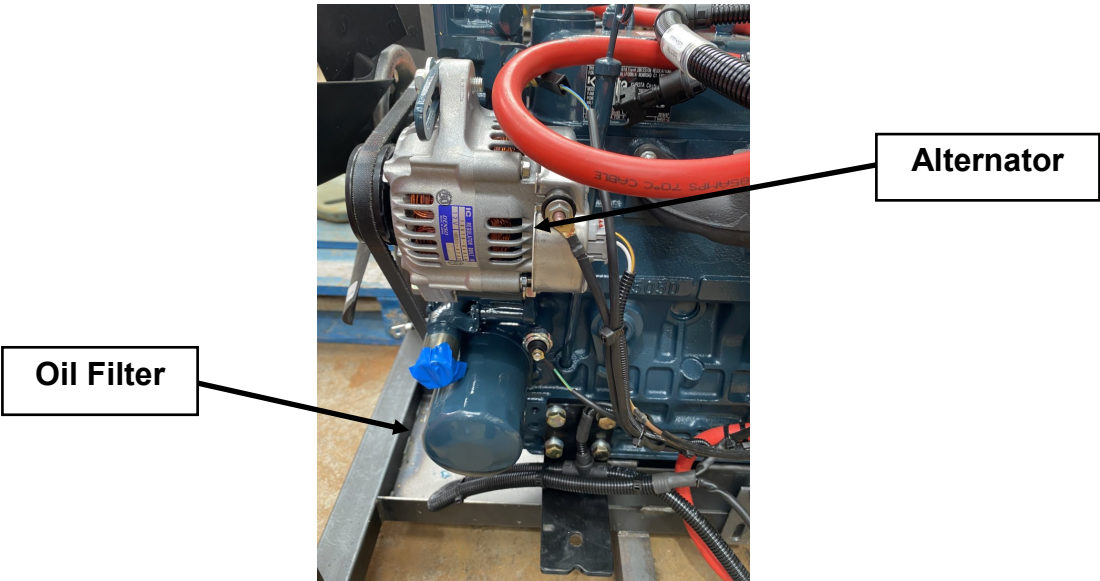

Air Filtration

The Air Filter Element is accessible through the rear right hand side access guard. Remove the element end cap and pull out the primary and secondary filters.

Daily- inspections cleaning out dust, for changes refer to the Kubota Engine Manual.



Air Filter Element



Air Filters

Fuel System

The fuel filter is located at the front of the engine through the rear access door.

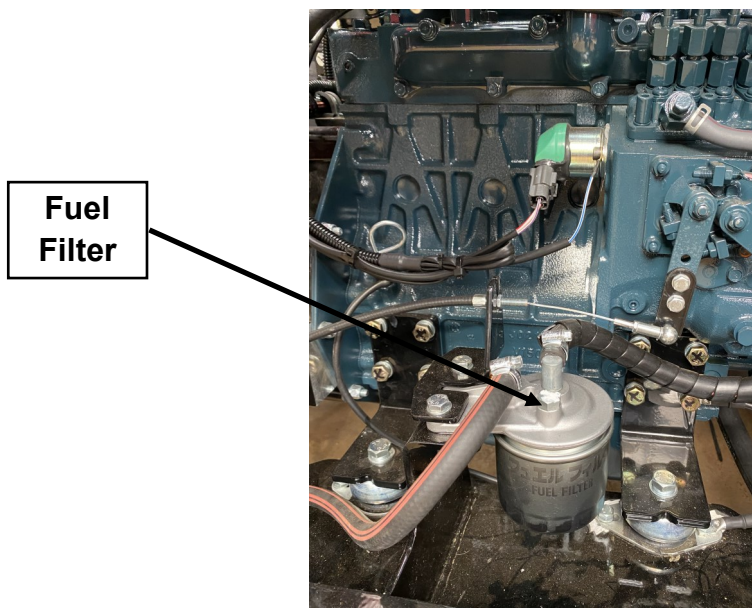

**Fuel
Filter**

Cooling System

The radiator cooling system is filled through the filler cap on top of the header tank. The coolant level gauge is on the front face of the tank.

Daily—check the fan belt adjustment and the condition, referring to the Kubota Engine Manual.

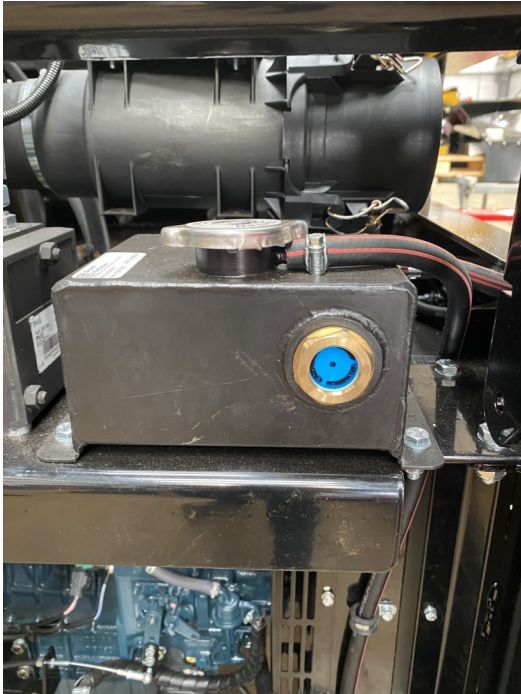

Header Tank

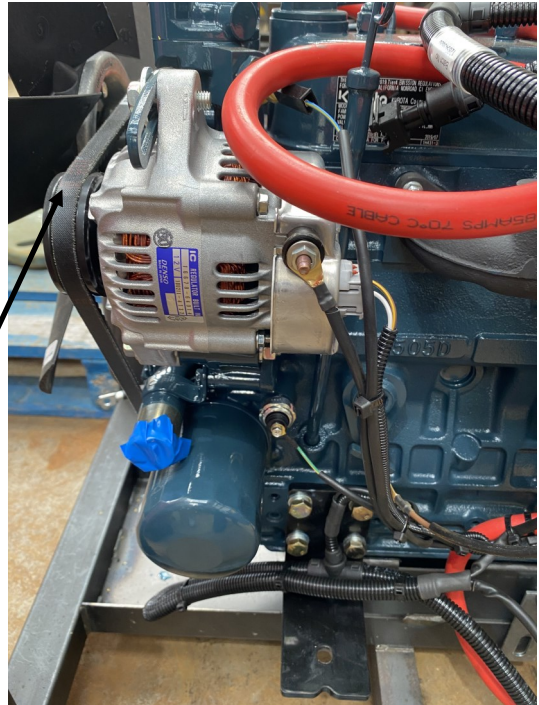

Fan Belt

Engine

Greasing

1. Vibrating feeder gearbox grease point.
2. Jaw assembly greasing point.
3. Conveyor Greasing — two bearings on head-drum

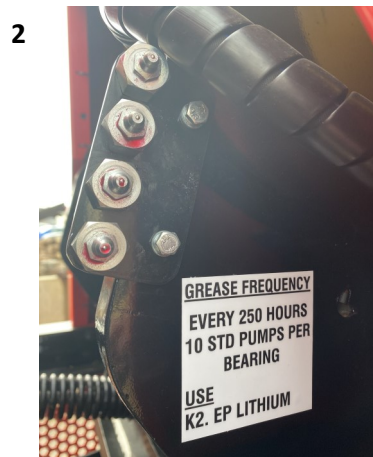
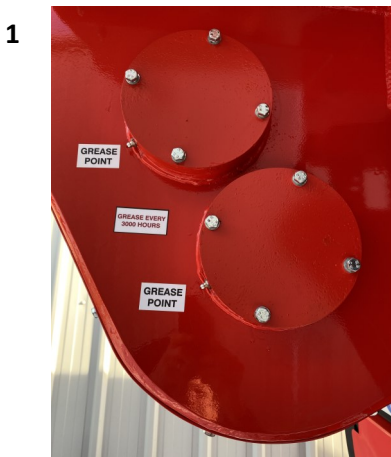

Hydraulics

The Hydraulic Oil tank is accessible through the side panels of the machine and situated behind the engine. Check the oil level via the side gauge. Unscrew the filter elements to pull out filters. Clean and check every 100 hours and replace every 1000 hours.

OIL FILTER
CAP

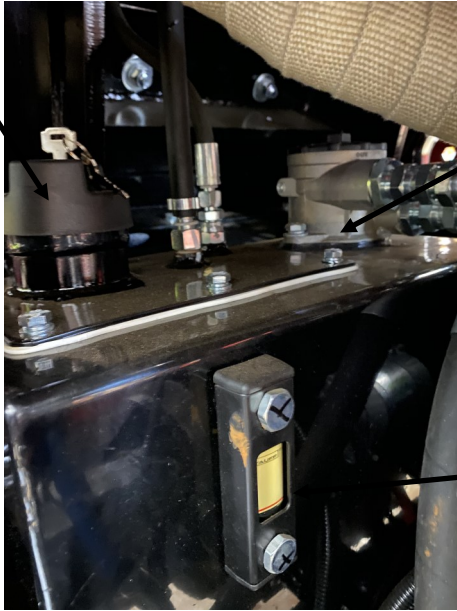

HYDRAULIC
FILTER

LEVEL
GUAGE

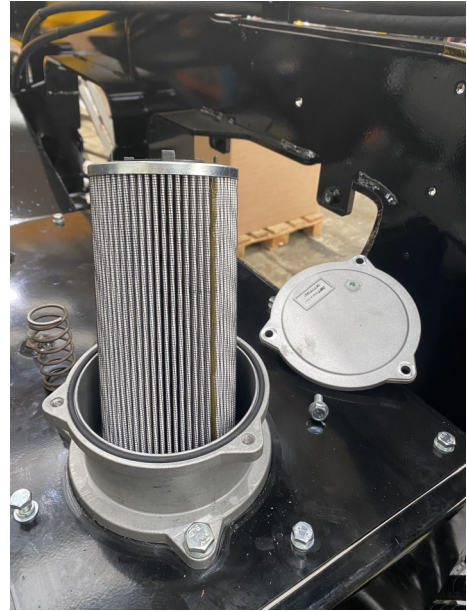

Hydraulic Filter

CRUSHER

Check the jaw plates for wear, if evident reverse or replace plates. Check the drive belt for alignment damage and tensioning.

Contact Red Rhino service for their jaw maintenance procedures.



Jaw Box



TENSIONING
ROSTA

Emergency Stop Buttons

Check all the emergency stops are working daily to ensure maximum safety.

These can be located on either side of the machine.



Tracks

Check track gearbox oil levels every 500 running hours. Check track tension daily and apply **EP2** grease to tension when required.

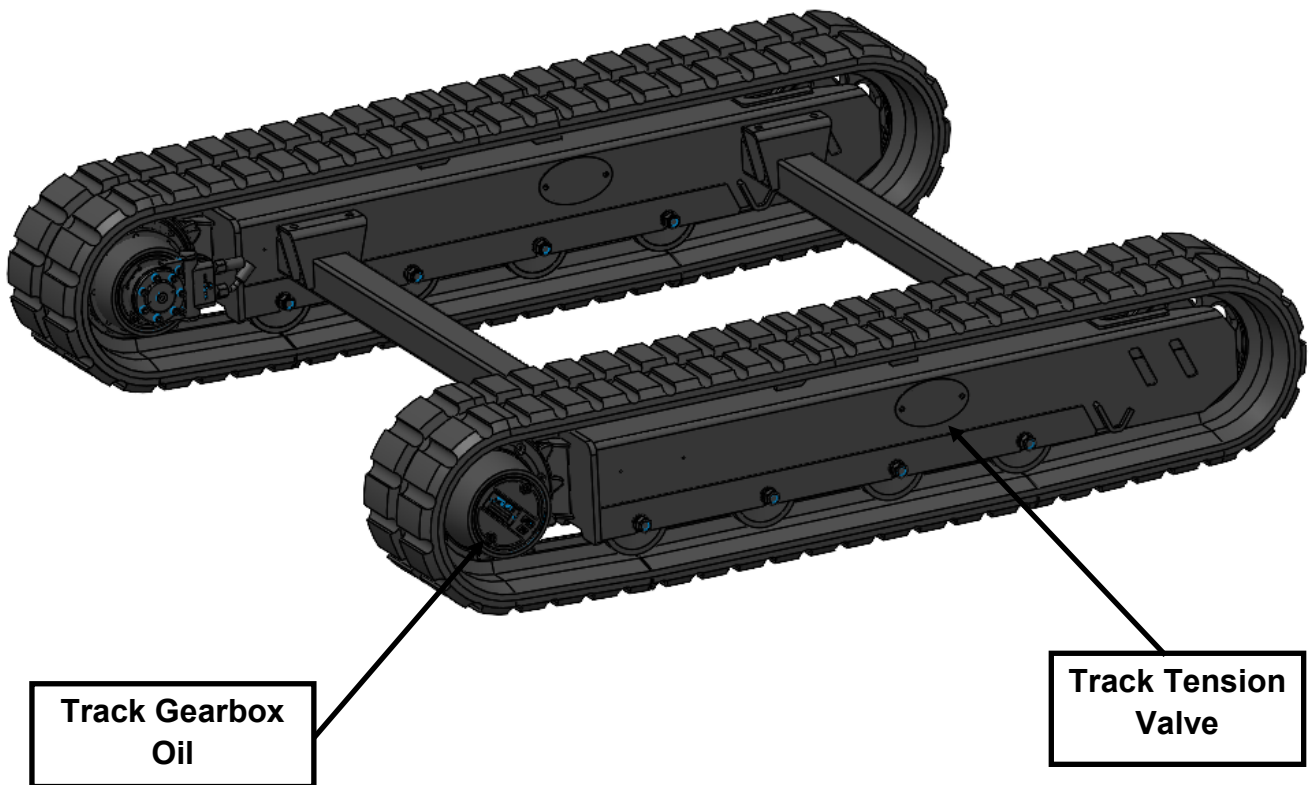

Hydraulic Manual Controls

In the event of a system electrical failure a back up manual operation of all machine functions can be applied. This is an emergency function and does not allow the machine to run normal conditions.

Hydraulic Spool Levers

Situated above the engine access through the rear engine door. These manual levers operate each function temporarily as a back-up system.

i.e. - Tracking.

- Running clear jaw, conveyor and feeder of crushed material.
- Unblocking jaw.

Note: This system is for recovery or maintenance in the case of electronic failure only.



Left Hand
Spool Feeder/ Conveyor

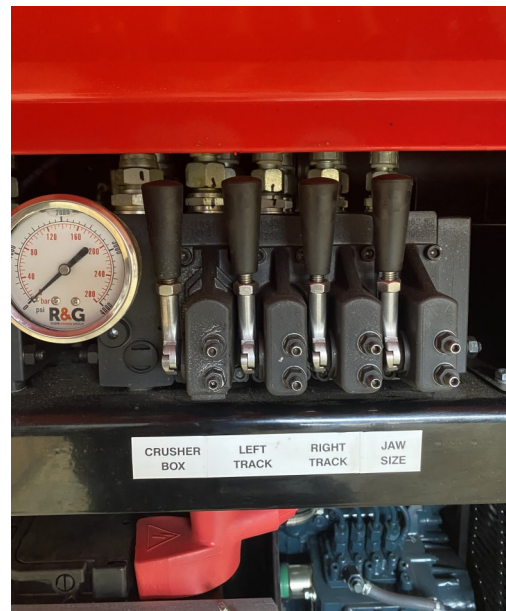

Right Hand
Spool Crusher/ Tracks/ Jaw

Service Data Gauges

The spools also have pressure gauges to obtain system pressure information.

These are a useful aid to diagnose the hydraulic issues for Red Rhino Service.

Hydraulic Circuit

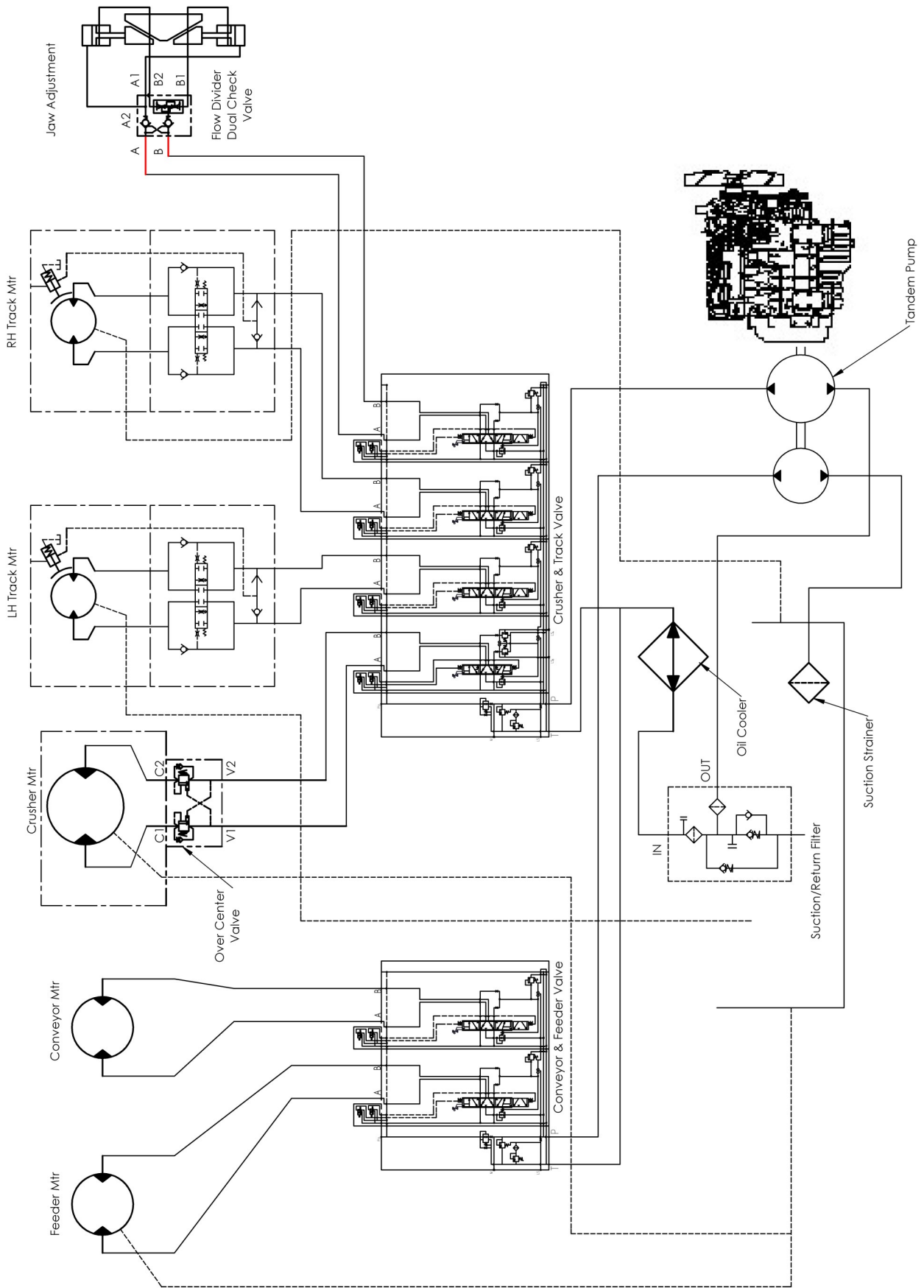

Engine Harness

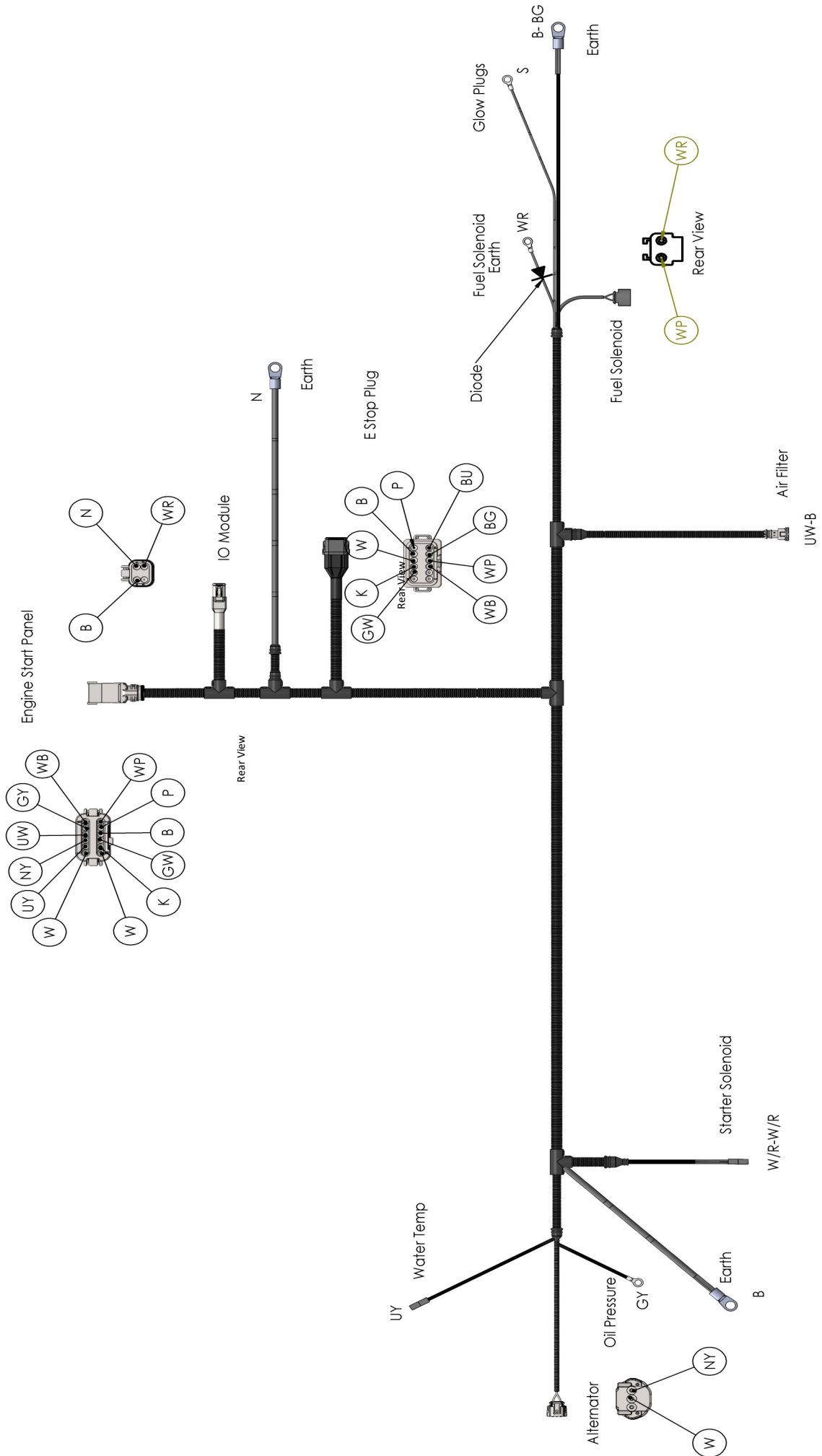

E Stop Harness

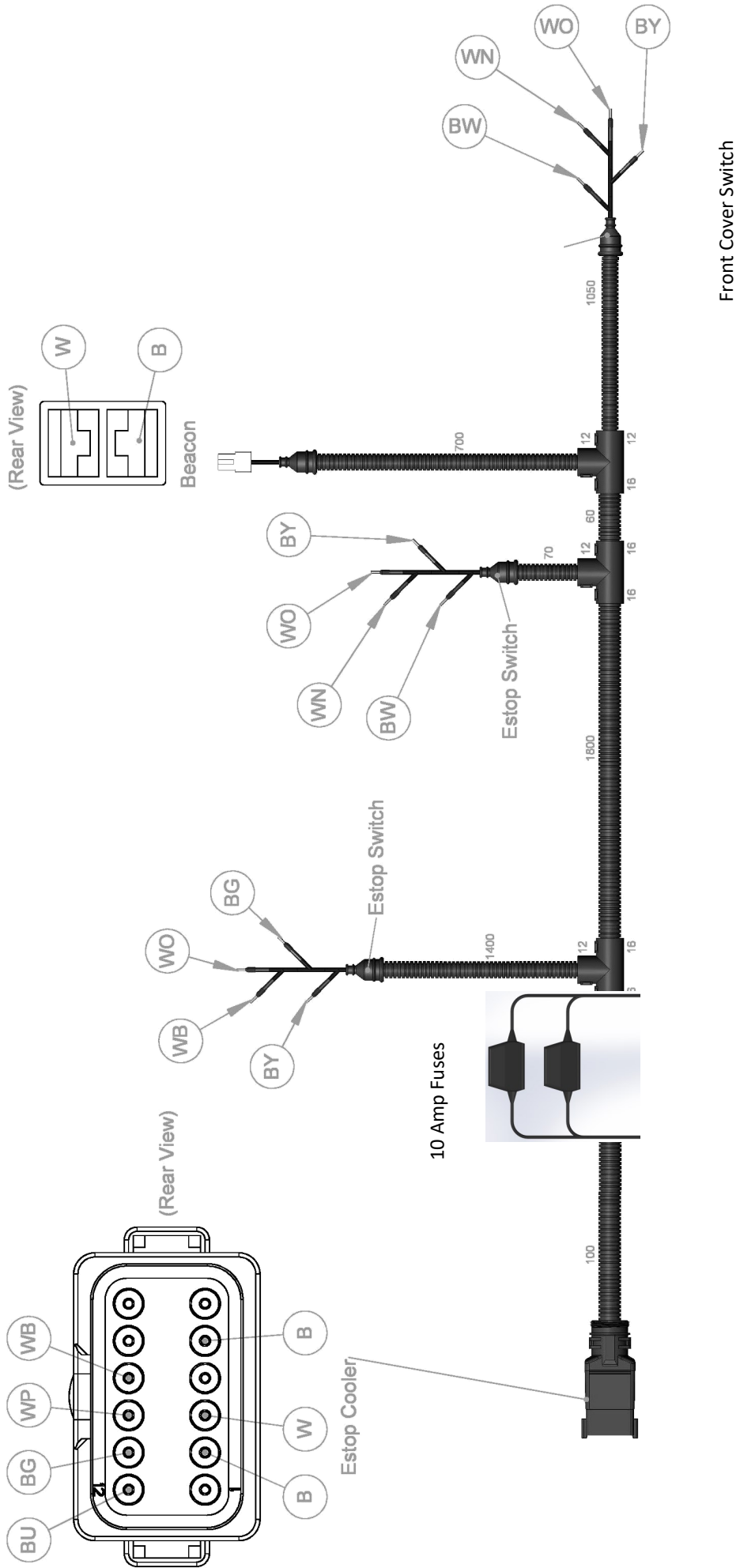

Optional Extra — Over Band Magnet

Benefits

The addition of magnet arms will remove any magnetic objects that may have passed through the crusher, preventing them from ending up in the final stock pile. These materials can damage the conveyor belt and effect the purity of the end product.

**MAGNET
ARMS**



Over Band Connection

The over band magnet is suspended from a support frame fixed to the chassis member.

**DISHCHARGE
SIDES**



Stock Pile Sorting

The magnet picks up material that can be discharged to the left or right hand side by switching the hydraulic flow connections over.

**HYDRAULIC
CONNECTIONS**



Hydraulic Connection

The feed and return oil supply is connected by quick release coupling adaptors inside the left hand front end chassis.

Optional Extra - Feeder Sensor Sonar

Optional Extra — Screening Attachment

Benefits

The addition of the RRC 5000 screener is one of the most effective ways of sorting the processed material, otherwise impossible by hand. The screener attachment will sort the previously crushed material through a screener via the momentum of the machine, into useful stock size piles, dependant on mesh. Pairing the crusher with a screener creates a production line to a useful/ useable end product for recycling or selling.



Fines Material Direction

Screener Motion

The Screener attaches to the end section of the conveyor via six elasticated bobbins. The screener is non-driven and gains its momentum by the vibration of the conveyor through the rubber bobbin.



Oversized Material Direction

Material Sorting

A single deck mesh is fitted to the screener deck. This denotes the size of the aggregate required. Material is fed from the crusher conveyor over the mesh as the oversize grade. Material passing through the mesh is the finer grade. Both aggregates are channeled in opposite directions to form stockpiles.

Replacement Parts



For replacement parts and / or spares you will need to quote the Red Rhino model and engine serial number.

Red Rhino will provide an additional recommended Spares List for your machine.

These are available from the Red Rhino Parts and Service Department.

Please email service@redrhinocrushers.net

or call +44 (0) 1476 590790.

Model Specifications

	Model	5000 Plus	
Vibrating Feeder General Data	Prime Mover Type	Internal Combustion Engine	
	Power Installed	18.5kW (24.8hp)	
	Overall dimensions in operating mode	Length	5600mm
		Length - less conveyor	4100mm
		Width	1665mm
		Height	2080mm
	Mass in operating mode	3170kg	
	Mass in transporting mode	3170kg	
Ground Clearance	142mm		
Detailed data for Internal combustion engine	Manufacturer	Kubota	
	Model Name	V1505-Stage V emission compliant	
	Net Power	18.5kW (24.8hp)	
	Rated Revolutions	2300 r/min	
	Fuel type	Diesel	
Detailed data for feeder hopper	Type	Fixed	
	Size (Charging width x Charging length)	1040mm x 1350mm	
	Charging Height	1880mm	
Detailed data for vibrating feeder hopper	Type	Vibrating Hopper	
	Size (Charging width x Charging length)	1008mm 2090mm	
	Charging Height	1880mm	
Detailed data for crushing device	Type	Hydraulic Jaw	
	Feed opening device	500mm x 250mm	
	Discharge setting range	20mm – 100mm	
	Revolutions operating	280 rpm	
	Drive type	Hydraulic / Mechanical	
Detailed data for discharge device	Type	Belt Conveyor	
	Width x Length	400mm x 3200mm	
	Discharge height	1520mm	
	Drive type	Hydraulic	
Detailed data for Travel device (crawler mounted)	Track shoe width	250mm	
	Track length (Sprocket / Idler)	1395mm	
	Ground contact pressure (average)	42.1 KPa (6.1 PSI)	
	Maximum travel speed	1 km/h	
	Drive type	Hydraulic	
Detailed data for tank capacities	Fuel	47L	
	Hydraulic oil	50L	
	Engine oil	6L	

General Arrangement Dimension

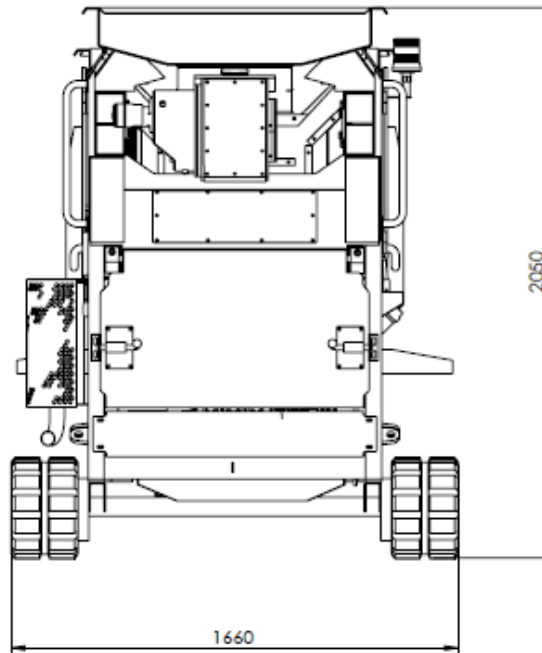

Rear View

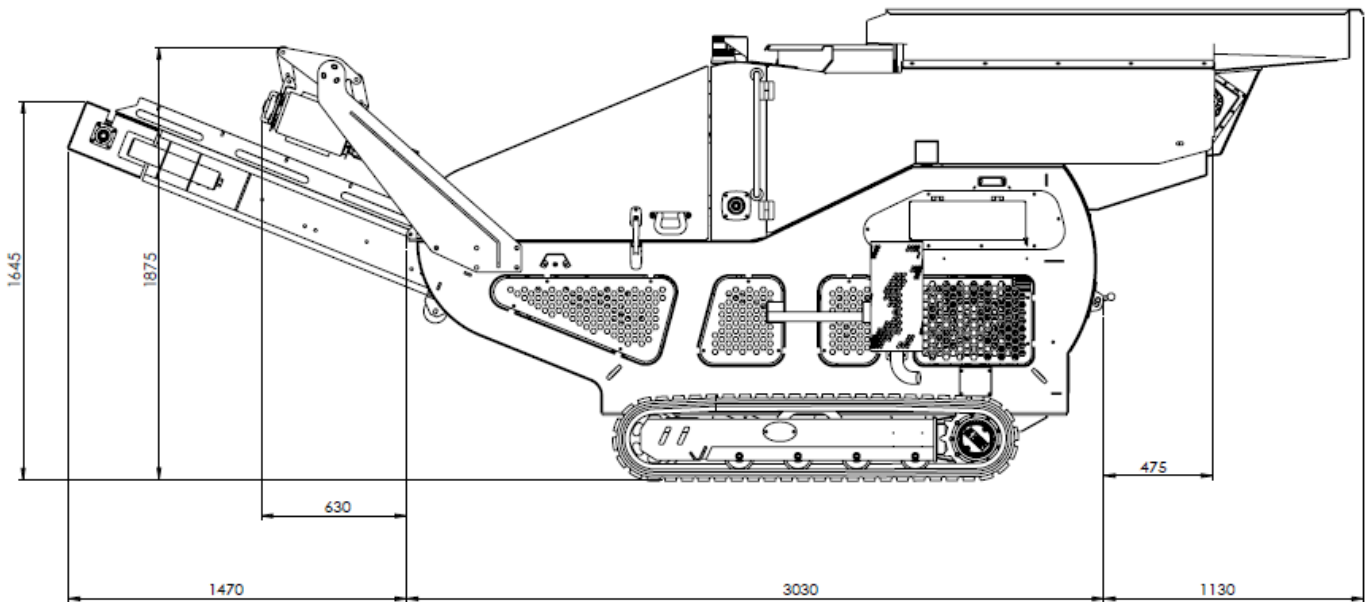

Side View

RED RHINO MINI CRUSHERS (UK) LTD.

NOISE EMISSION DATA IN ACCORDANCE WITH –

MACHINERY DIRECTIVE 2006/42/EC

OUTDOOR NOISE DIRECTIVE 2000/14/EC

NOMAD (9) 2016 NOISE MACHINERY PROJECT.

Equipment Type - **RED RHINO MODEL 5000Plus**

THIS EQUIPMENT HAS THE FOLLOWING NOISE EMISSION DATA COMPILED – **NOVEMBER 2022**. UNDER NON- CRUSHING CONDITIONS.

A Weighting – A standard weighting of the audible frequencies designed to reflect the response of the human ear to noise

All measurements were taken in a Hemispherical Order with 1 Meter radius around the Crusher.

MEASUREMENTS 1 – 4 - Ambient background reading machine non – functional

MEASUREMENTS 5 – 8 – Machine Operational at full running speed. All Functions engaged.

POSITION 1 72..... Sound Level dB (A)

POSITION 2 72.1... Sound Level dB (A)

POSITION 3 72.9... Sound Level dB (A)

POSITION 4 73 Sound Level dB (A)

POSITION 5 ...98.7...Sound Level dB (A)

POSITION 6 97.7...Sound Level dB (A)

POSITION 7 94..7 ...Sound Level dB (A)

POSITION 8 ...96.9...Sound Level dB (A)

Mean Reading 1 – 4 ...72.5.... dB (A)

Mean Reading 5 – 8 ...97... . dB (A)

The noise levels recorded are above the guidance regulations of 80 dB(A)

Owners should enforce the operational use of **Hearing Protection** and conduct their own noise **Risk Assessment** within their operational surroundings.

PLEASE BE ADVISED

These readings were carried out in a non- crushing condition, materials being crushed may produce greater noise levels. Appropriate PPE protection should be applied. Further tests carried out to determine operational levels of noise omitted when materials are being crushed should be carried out by Owner / Operator.

EDITION NOVEMBER 2022

Conclusions/Recommendations for Action

The noise level at the operators position at the controls of the machines is in excess of the second action level of 85dB (A) which under the Control of Noise at Work regulations 2005 action levels requires that hearing protection must be worn (operators of the machine should conduct their own noise exposure risk assessment to determine the risk to anyone operating the machine).

The levels of noise in excess of 80dB (A) produced extend beyond the 1 meter boundary and so all persons working within the 5m boundary should wear hearing protection.

Different materials may produce greater levels of noise and so if there is any doubt about the noise levels, hearing protection should be worn and further measurements should be taken to determine the levels.

Warning signs or labels should be applied to all machines stating that hearing protection must be worn whilst in use even if not crushing. An example is shown below.



HEARING PROTECTION MUST BE WORN!

Owners of a Red Rhino machine should carry out further noise testing and risk assessments to reflect the relevant site conditions where the machine is in operation.